

COMMERCIAL DATA SHEET

Alpine XR



Billi Alpine 125 with XR Remote Dispenser

Enjoy refreshing chilled or a continuous supply of ambient temperature filtered water. Billi's Alpine 125 offers a premium filtered drinking water experience to account for all preferences. The XR remote dispenser is an innovative and thoughtful design, with the potential for ambulant or wheelchair inclusive access via the remote control panel.



XR Remote Dispenser

Alpine Under-Bench Unit



Features

- SPACE SAVING DESIGN
- ENERGY EFFICIENT
- NO CUPBOARD VENTILATION REQUIRED
- UNLIMITED FILTERED WATER
- ADJUSTABLE CHILLED TEMPERATURE
- WATER COOLED TECHNOLOGY
- RANGE OF FINISHES
- EASY INSTALLATION
- AUSTRALIAN DESIGNED & MADE
- HACCP CERTIFIED

PRODUCT SPECIFICATIONS

Water type	Product code	Model name	Dispenser	Suggested no. of people	Chilled water delivery (cups per hour)	Still water delivery (cups per hour)	Power supply (amps)
 STILL CHILLED	932125R	Alpine 125	XR Remote	Up to 40	120	unlimited	10

Accessories

992800 - 70mm Riser & Font

992820 - 70mm Riser

992803 - 120mm Riser & Font

992830 - 120mm Riser



990720 - Tubing Extension Kit for X series dual temp dispensers 2mtrs

Finishes

Standard Finish

CH - Chrome

Add the Finish code to the Product Code to finalise your specification, eg. 932125RCH

TECHNICAL DRAWING & INSTALLATION REQUIREMENTS

PRODUCT DIMENSIONS

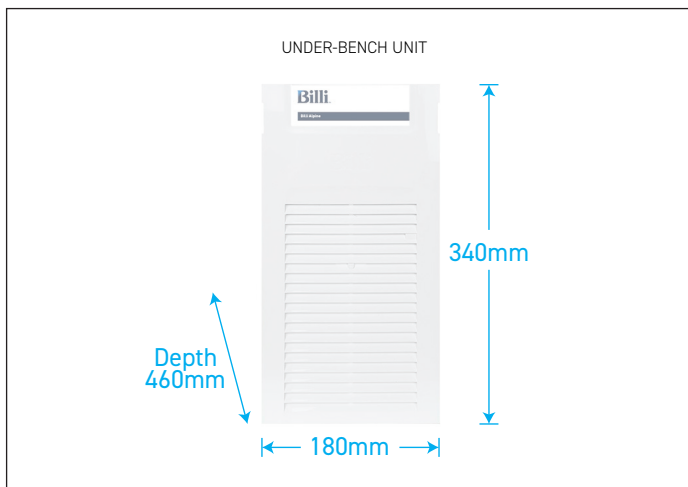
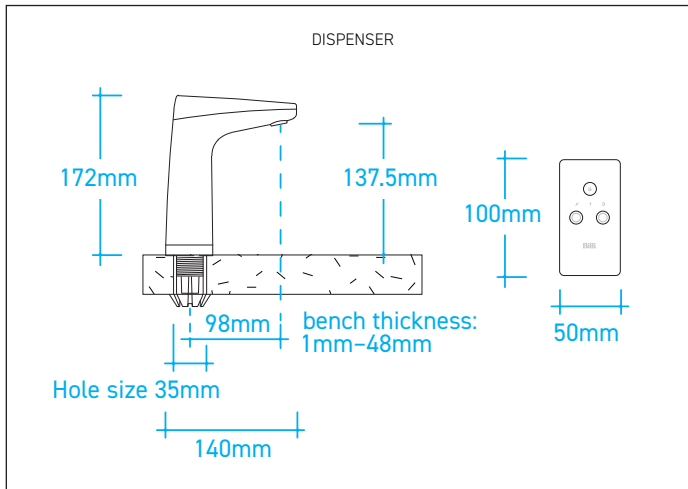

PREFERRED INSTALLATION LAYOUT

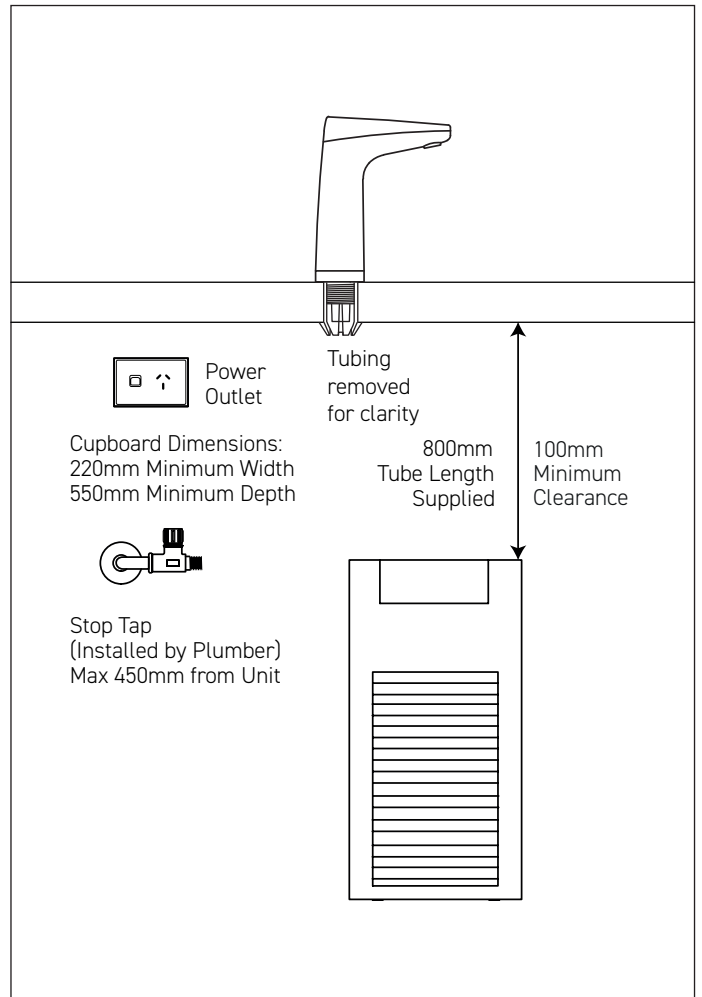

WATER SUPPLY

A single 1/2" BSP (15mm) stop-tap with a male thread should be installed in an easily accessible position. Water supply must be microbiologically safe to drink, with a minimum dynamic water pressure of 250kPa and a maximum of 1000kPa.

POWER SUPPLY

A standard 10 amp power outlet is required, no further than 1000mm from the underbench unit. The system is supplied with a 1 metre flex cord and plug.

FILTRATION

Billi's range of premium filters utilise BWT's unique Fibron X technology. Billi's filter range provides superior taste, water quality, consistent filter life and peace of mind when it comes to hygiene.

Filter supplied: 994051 (5 micron). Replacement filters available: 994052 (0.2 micron), 994054 (HSD), 994055 (XPHSD), 994056 (Sediment only) and 994060 (0.2 micron sediment only).

CERTIFICATIONS

Every Billi drinking water appliance is manufactured under a certified quality control system. All Billi commercial range models have been tested and comply with all required standards including: Watermark: WM-021882; HACCP: PE-872-WAT-1-02; ISO 9001:2015, QEC 11627; Tested to ATS5200.105 and AS/NZ 4020; QEC 11627; Section J6.6 of the BCA; WELL Cornerstone Member.

WARRANTY

The Billi Alpine Range is covered by a comprehensive 2 year warranty on all parts and labour.

Billi™

Billi Australia Pty Ltd
42 Lucknow Crescent,
Thomastown, Victoria
3074 Australia

P 1800 812 321
F +61 3 9469 0499
W www.billi.com.au

visit us at



Designed and manufactured in Australia to the highest quality standards