

# COMMERCIAL DATA SHEET

## Alpine Sparkling 200 Dual Levered



### Billi Alpine Sparkling 200 with Dual Levered Slimline Dispenser

The Alpine Sparkling 200 delivers instant chilled and sparkling filtered drinking water making it the perfect addition to any kitchen, entertaining zone or hydration station.

The professional grade sparkling system utilises ice bank technology to enhance delivery & recovery.

The system offers adjustable carbonation supplied from a dual levered slimline dispenser, which is both streamlined and elegant.



Dual Slimline Dispenser

Alpine Sparkling Under-Bench Unit



### Features



\* Italian designed Sparkling module

## PRODUCT SPECIFICATIONS

Water type	Product code	Model name	Dispenser	Suggested no. of people	Chilled & Sparkling water delivery (cups per hour)	Power supply (amps)
 CHILLED SPARKLING	933200D	Alpine Sparkling 200	Dual Slimline	Up to 80	200	10

### Accessories

**992810** -Slimline Font

**990727** - Tubing Extension Kit for Slimline Sparking 2mtrs



### Finishes

Standard Finishes

CH - Chrome

BR - Brushed

MB - Matte Black

Add the Finish code to the Product Code to finalise your specification, eg. 933200DMB

# TECHNICAL DRAWING & INSTALLATION REQUIREMENTS

## PRODUCT DIMENSIONS

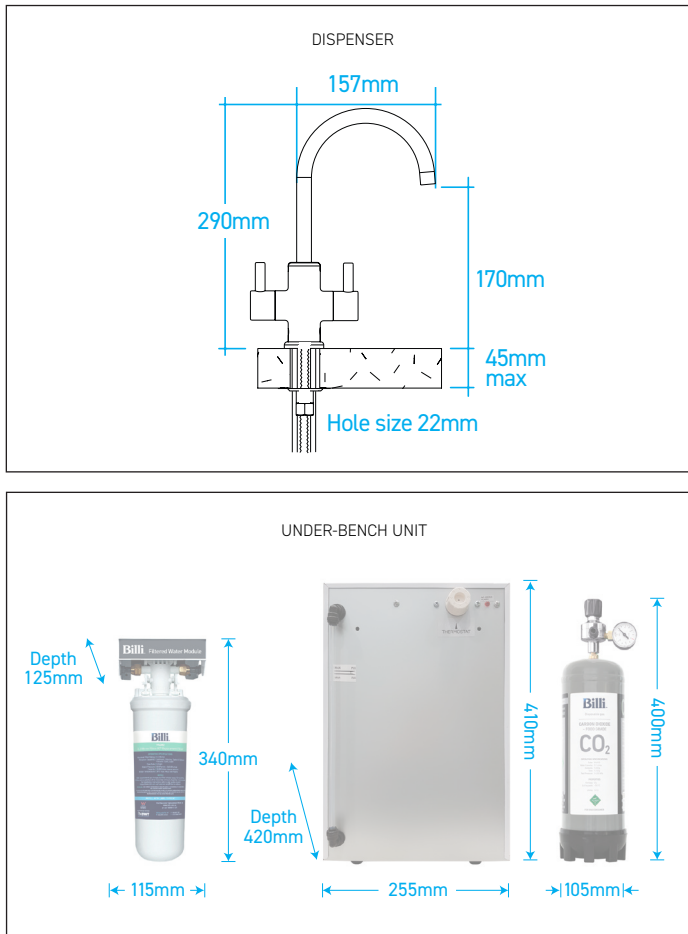

## PREFERRED INSTALLATION LAYOUT

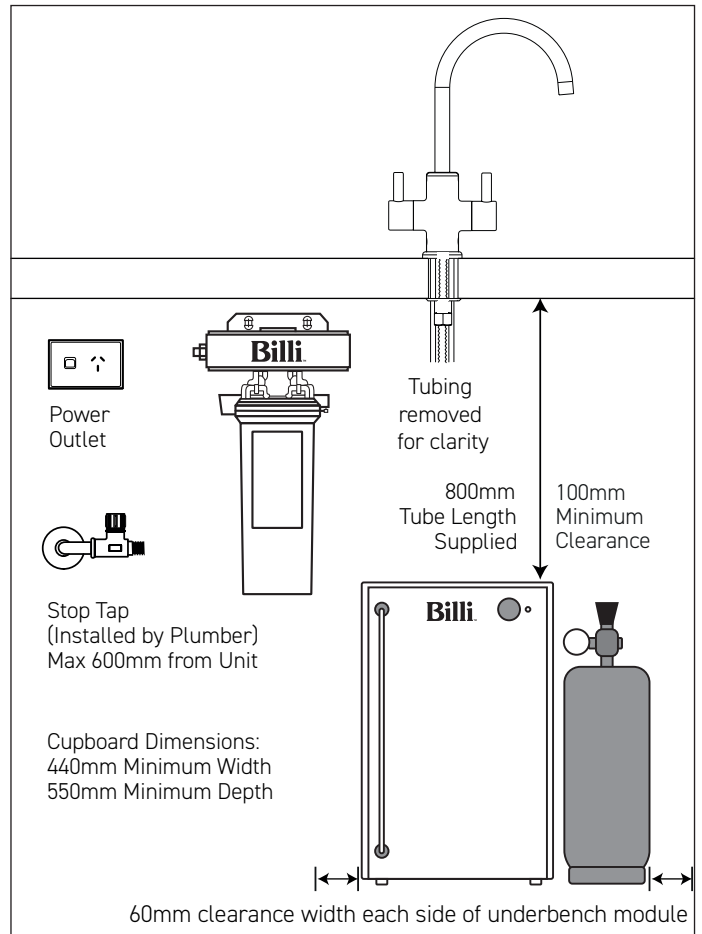

### WATER SUPPLY

A single 1/2" BSP (15mm) stop-tap with a male thread should be installed in an easily accessible position. Water supply must be microbiologically safe to drink, with a minimum dynamic water pressure of 250kPa and a maximum of 1000kPa.

### POWER SUPPLY

A standard 10 amp power outlet is required, no further than 1000mm from the underbench unit. The system is supplied with a 1 metre flex cord and plug.

### FILTRATION

Billi's range of premium filters utilise BWT's unique Fibron X technology. Billi's filter range provides superior taste, water quality, consistent filter life and peace of mind when it comes to hygiene.

Filter supplied: 994051 (5 micron). Replacement filters available: 994052 (0.2 micron), 994054 (HSD), 994055 (XPHSD), 994056 (Sediment only) and 994060 (0.2 micron sediment only).

### CERTIFICATIONS

Every Billi drinking water appliance is manufactured under a certified quality control system. All Billi commercial range models have been tested and comply with all required standards including: Watermark: WM-022690; Tested to ATS5200.105 and AS/NZ 4020; ISO 9001:2015, QEC 11627; WELL Cornerstone Member; HACCP PE-872-WAT-1-02.

### CO<sub>2</sub> Cylinder

The CO<sub>2</sub> gas cylinder supplied must be secured in a suitable location. Each cylinder contains 1100g of CO<sub>2</sub> and should be installed in a well ventilated area. Each cylinder will provide between 200-350L of sparkling water depending on the unit settings. The MSDS is available on [www.billi.com.au](http://www.billi.com.au) for a complete list of specifications and warnings. Replacement gas cylinders are available from Billi. CO<sub>2</sub> Cylinder - single 996911 or double 996912.

### WARRANTY

The Billi Alpine Range is covered by a comprehensive 2 year warranty on all parts and labour.

# Billi™

Billi Australia Pty Ltd  
42 Lucknow Crescent,  
Thomastown, Victoria  
3074 Australia

P 1800 812 321  
F +61 3 9469 0499  
W [www.billi.com.au](http://www.billi.com.au)

visit us at



Designed and manufactured in Australia to the highest quality standards