



Billi®

Superior Instant Filtered Water



BOILING



CHILLED



SPARKLING



STILL

Designed and manufactured in  Australia to the highest quality standards

Billi®

Originating in Australia, Billi has been at the forefront of the instant filtered boiling and chilled water systems industry for over 30 years. Billi products are celebrated for their combination of functionality, performance and contemporary aesthetics. Proudly Australian-made and designed, Billi products have brought a unique concept of underbench instant filtered boiling, chilled and sparkling drinking water to many countries around the globe.

Manufactured in Melbourne, Australia to strict quality standards, Billi water systems come with an assurance of quality, innovation and sustainability. Incorporating cutting edge eco-technology features and modern designs, Billi delivers solutions that keep pace with the ever-changing needs of its users.

CONTENTS

About Billi	p.03
Why Billi	p.04
Billi Service	p.05
Product Features	p.06
IWBI Membership	p.08
Billi Technology	p.10
Premium Filtration	p.12
Billi Case Studies	p.14
How to choose your Billi	p.16
Multifunction Mixer Tap	p.18
OmniOne	p.20
Product Range	p.22
Billi 3D Build	p.35
Accessories	p.36
On Wall & Bubbler	p.38
Touchless Washroom Systems	p.40
Technical Drawings	p.42
Warranty & Certifications	p.44
What customers say about Billi	p.46

Designed and manufactured in  Australia to the highest quality standards

WHY BILLI

Synonymous with innovation, Billi prides itself on being the leading designer and manufacturer of boiling, chilled, sparkling and still filtered water systems.

With all Boiling & Chilled units manufactured in Melbourne, Australia, we are uncompromising on quality and dedicated to delivering the most reliable, high performance and stylish products on the market.

The Billi range of products include industry leading features such as water-cooled technology, space saving underbench footprints, specialty dispensers, plus a large range of models that do not require cupboard ventilation cut outs or grilles. This makes our units easy to install, energy efficient and user-friendly for all.

CUSTOMER FOCUS

In every interaction with Billi, our commitment to the highest levels of customer service is evident.

Billi's unequalled aftersales care and product support, ensures that our valued relationship with our customers does not end at purchase.

Billi goes a step further with dedicated teams servicing each of our markets to ensure specialised care relevant to your requirements.



Matte Black XL Levered Dispenser with matching Square Mixer Tap

BILLCARE SERVICE PLANS

BilliCare offers our customers the very best in innovation, superior performance and reliability, and support this with a world class customer service experience.

Instant filtered drinking water systems require maintenance and filter replacements to ensure optimal water quality and an ongoing high level of performance. Our commitment is to make it easy for you.

Our Billi Customer Support team includes an Australia-wide network of trained service technicians and service agents to provide technically correct, prompt and reliable service.

For more information on our service plans, please visit our website.

[EXPLORE MORE](#) Search: [BilliCare Service Plan enquiry](#)

Contact your local Billi team for more information on our range of service plans.



Silver Service Plan



Gold Service Plan



4 Year Service Certificate



Billi Installation



Refillable CO2 Filter Plan

Service Plan Benefits*

- Reduce costs and downtime
- Manufacturer direct servicing ensures genuine filters & parts
- Preventative maintenance ensures trouble-free operation & peace of mind
- Only accredited service technicians and agents will service your systems
- Work with a single service company nationally to simplify asset management

Plumbing licenses: WA PL10956, QLD 15089576, NSW 392108C, SA PGE5081.

*Benefits will vary depending on plan chosen.



**SPACE SAVING DESIGN**

With a focus on space saving, Billi systems have one of the smallest footprints on the market, allowing you to make the most of the valuable underbench space.

**SAFE TO OPERATE**

All dispensers offering boiling water are supplied standard with a safety switch to lock off access to boiling water where needed. The red lock icon demonstrates when the safety switch is activated. Simply touch the sensor switch to release the lock and activate the boiling water. The dispenser will revert to safety mode after a period of non-use.

**SPLASHFREE DELIVERY**

Billi's Splashfree boiling water delivery electronically varies the water flow, slowing momentarily to eliminate splashing as the water first enters the cup.

**ENERGY EFFICIENT**

Billi's unique Heat Exchange Technology enables our systems to achieve substantial energy savings. Our units also feature a standby mode which conserves energy by powering down after 2 hours of non-use.

**HEAT EXCHANGE TECHNOLOGY**

Billi's unique heat exchange & energy reclaim technologies recovers the waste heat energy produced in the chilling process to preheat the boiling water. This allows boiling water to reach optimal temperature more efficiently while achieving substantial energy savings.

**WATER-COOLED or AIR-COOLED TECHNOLOGY**

Billi are the only manufacturer to offer both water-cooled and air-cooled options. Our water-cooled systems utilise heat exchange & energy reclaim technologies and are more energy efficient than our air-cooled systems. Billi's heat exchange technology ensures water usage is minimal. Billi's air-cooled options generate far less heat than traditional air-cooled systems.

**NO CUPBOARD VENTILATION REQUIRED**

Billi's Water Cooled systems do not require cupboard ventilation or a cooling fan and operate a lot quieter than air cooled systems.

**ADJUSTABLE CHILLED TEMPERATURE**

A simple adjustable control knob allows the chilled water temperature to be raised to 15°C or lowered to 6°C for perfectly chilled, refreshing drinks. Your desired temperature is reached quickly and maintained efficiently during operation.

**ADJUSTABLE SPARKLING LEVEL**

Adjust the level of sparkling to suit your taste, with adjustable controls up to 5 bar of CO₂ pressure.

**ICE BANK TECHNOLOGY**

Our Ice bank technology has a chilled reservoir where both sparkling and chilled water supply passes through. In doing so, the dispensed water temperature is consistently chilled, also providing a higher level of carbonation.

**PLUS MODELS AVAILABLE**

Billi's PLUS models can function as your hot water service providing hot and cold water, as well as boiling, chilled, sparkling or still water. PLUS models also feature a boiling water reserve to ensure you will have a boiling water supply after the hot water supply is fully drawn. Ideal for areas without a hot water supply.

**UNLIMITED FILTERED WATER**

The Billi Alpine, Sahara, Quadra and Filter Tap ranges all offer a bottomless supply of still filtered water.*

**ECO-INTELLIGENCE TECHNOLOGY**

The Billi Eco & Sahara systems incorporate Eco-Intelligence technology which is a self learning timer allowing the unit to only operate when required. The self learning timer monitors daily usage patterns and even recognises evening and weekend changes in routine to effectively minimise energy consumption.

**CHOICE OF DISPENSER DESIGNS**

A wide array of fit-for-purpose and designer options are available to suit all specifications. Ranging from our commercial flagship X-series with DDA compliant accessories such as braille or vision contrast levers, through to mechanical Slimline dispensers or the award-winning and newly released Multifunction Mixer Tapware in a range of architectural finishes.

**EASY INSTALLATION**

By eliminating the need for cupboard cut outs, our units are quick, easy and safer to install. Our units also feature a self commissioning function making setup simple and efficient.

**AUSTRALIAN DESIGNED & MADE**

All Billi units are designed and manufactured in Australia.

**ACCESSORIES**

Billi has a range of stylish and functional accessories to match your needs including fonts, risers and tubing extension kits.

* Safety time-out features and the required filter changes for hygiene still apply.

IWBI MEMBERSHIP

During 2024, Billi once again pioneered the representation of the drinking water category by participating in the first iteration of the IWBI's 'Works with WELL' program, focusing on product certification.

The membership program at IWBI convenes, celebrates and fosters collaboration with companies and organisations who are leading the movement to advance human health in buildings and communities around the world. This dynamic framework allows Billi to tap into IWBI's expansive resources and knowledge and demonstrates Billi's alignment with IWBI's mission.



"IWBI focuses on transforming health and wellbeing with our people-first approach to buildings, organisations and communities. As an IWBI Member, Billi has been an engaged contributor to the WELL movement since 2019 and we continue to enjoy a productive and collaborative relationship between our organisations within the region."

Jack Noonan, Vice President, International WELL Building Institute, Asia Pacific.

ABOUT IWBI

The International WELL Building Institute (IWBI) is leading the global movement to transform our buildings and communities in ways that help people thrive.

WELL v2 is the current version of its popular WELL Building Standard, which will continue to be offered to the market, along with the WELL Community Standard, a district-scale rating system that sets a new global benchmark for healthy communities.

WELL is focused exclusively on the ways that buildings and communities, and everything in them, can improve our comfort, drive better choices, and generally enhance, not compromise, our health and wellness.

IWBI convenes and mobilizes the wellness community through management of the WELL AP credential, the pursuit of applicable research, the development of educational resources, and advocacy for policies that promote health and wellness everywhere.

For more information about IWBI and WELL, please visit: www.wellcertified.com



XL Levered Dispenser in Chrome finish with matching 70mm riser and font

WELL HYDRATION PACK - INNOVATION OPPORTUNITY



The Ultimate Hydration Pack!

- ✓ Combine water intake recommendation with visual reminder
- ✓ Environmentally friendly glass bottle

Product Code: 882032



Hydration Reminder Device

- Reminds you to stay hydrated throughout the day
- Easy to attach to your bottle
- Automatically turns on when you are working nearby
- Blinks when you forget to hydrate
- Office friendly – no audible alarms

Product Code: **882031**



Glass Water Bottle

- Large 1L capacity water bottle
- Durable borosilicate & BPA free
- Includes time indicators to achieve recommended water intake

Product Code: **882019**

Certification for Sustainability

The Global Greentag certification is much coveted by global manufacturing businesses for its evidence-based approach to sustainable product certification.

Billi has been repeatedly certified and re-certified by Global Greentag since 2012, at the Gold Level of the LCARate Program and possesses an Environmental Product Declaration under EPD EN 15804.

The program is recognised by rating tools such as Greenstar® Australia and New Zealand, NZ Homestar®, LEED® and BREEAM®, IS® Rating and WELL® features, encompassing:

- Building / Product Synergy
- Health & ecotoxicity
- Life Cycle Analysis – Water
- Life Cycle Analysis – Greenhouse Gas
- Corporate Social Responsibility



EXPLORE MORE Search: Billi GreenTag

Billi's Sustainable Technologies

A unique industry proposition, Billi's dual technology proposition incorporates the energy efficiency and heat transfer benefits of Water Cooling, with the water efficient Heat Exchange technology.

Water is a more effective conductor of heat than air and keeps the system running at much more consistent and efficient operating temperatures. This in turn saves on energy costs and reduces your carbon footprint.

Additionally, water cooled systems DO NOT require any fans, cross ventilation, clearance tolerances or joinery cut outs to keep the system cool.

Our Heat Exchange technology ensures waste heat is exchanged within the system to generate a viable source of heating energy and contributing to Billi's Net-Zero and Sustainable Development Goals.

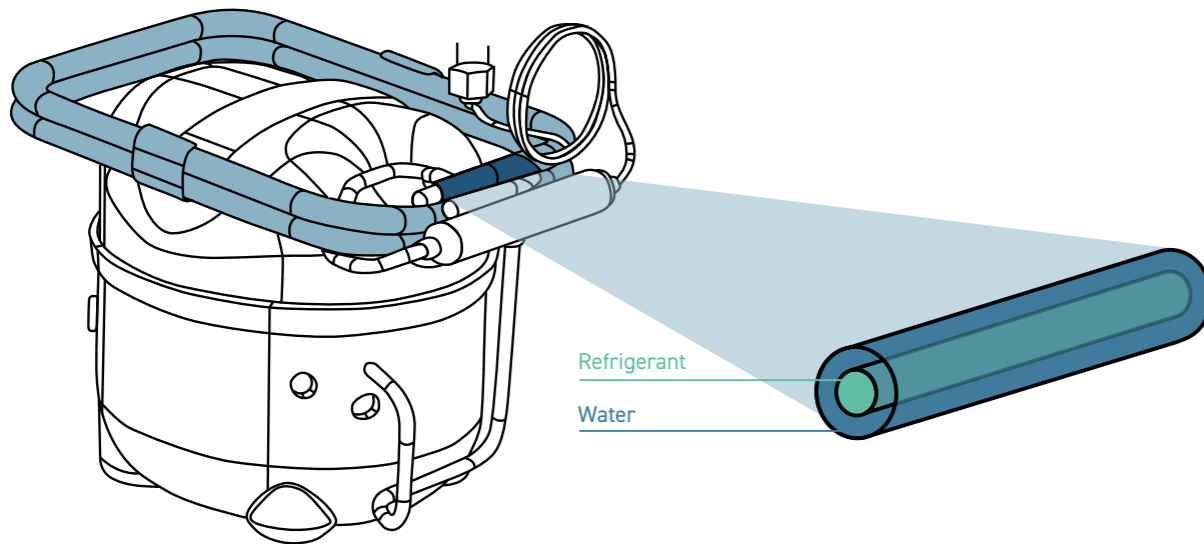

Billi compressor component shown, highlighting unique reclaim technology.

Unlocking a sustainable future begins with a shared commitment to the United Nations Sustainable Development Goals (SDGs) – a profound set of 17 interconnected objectives designed as a global benchmark. These goals intricately address the multifaceted challenges our world faces, setting the stage for a harmonious coexistence between people and the planet.

At Billi, we wholeheartedly embrace this global initiative by aligning our mission and practices with the UN SDGs.

Our pledge is more than a commitment; it's a proactive step towards contributing to the worldwide endeavour for a more equitable, sustainable, and inclusive world.

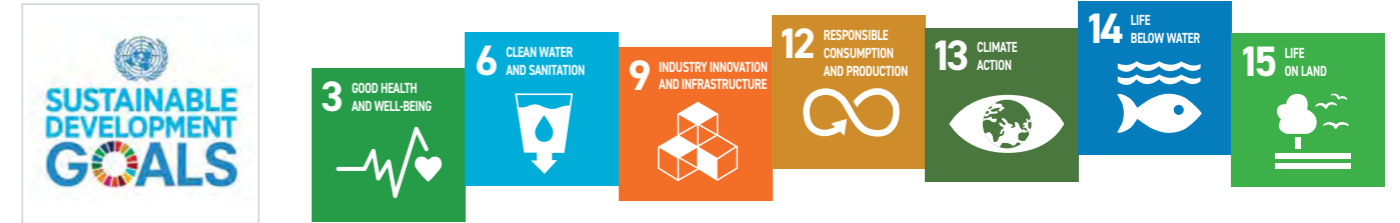

Our process

At Billi, sustainability and innovation stand as cornerstone principles within our operational framework. Our steadfast commitment to integrating sustainability across all aspects of our business model is evident from the outset. From the meticulous sourcing of raw materials to the thoughtful design of sustainable solutions and concluding with our rigorous recycling practices for both packaging and products, every step reflects our dedication to environmental stewardship.

SUSTAINABILITY IMPACT

Our sustainability journey transcends the traditional boundaries, reaching beyond the realms of manufacturing and product usage.

REDUCING CARBON FOOTPRINT

Our commitment to environmental responsibility is reflected in our range of water-cooled products. Certified by Global GreenTag, our water-cooled products boast a lower carbon footprint that is known & measurable.

WASTE REDUCTION

We recognise the urgent need to minimise all forms of waste, and to fulfill this commitment, we have forged strategic partnerships within the industry. These collaborations are designed to ensure the recyclability and re-use of materials wherever possible.

ENERGY SAVING

Billi's range of water-cooled products stands out for its innovative approach to sustainability. Our products possess the unique capability of converting waste heat into a valuable source of heating energy. By harnessing waste heat and turning it into a usable energy source, our water-cooled products exemplify a commitment to resourcefulness and environmental responsibility.

EMPOWERMENT & GOOD GOVERNANCE

Billi provides a supportive environment where our employees are not only encouraged but also empowered to embrace and promote sustainable practices in both their professional and personal lives. We are also empowered and guided by the measured principles of QMS and EMS Certification.

CERTIFICATION

Our dedication to environmental responsibility is underscored by our active participation in global initiatives like Global GreenTag, Works with WELL and our ISO 9001 QMS and ISO 140001 EMS Certifications.

WELLBEING

We proudly hold a Cornerstone Membership with the International Well Building Institute, a testament to our dedication to setting new standards in creating environments that prioritise health and well-being.

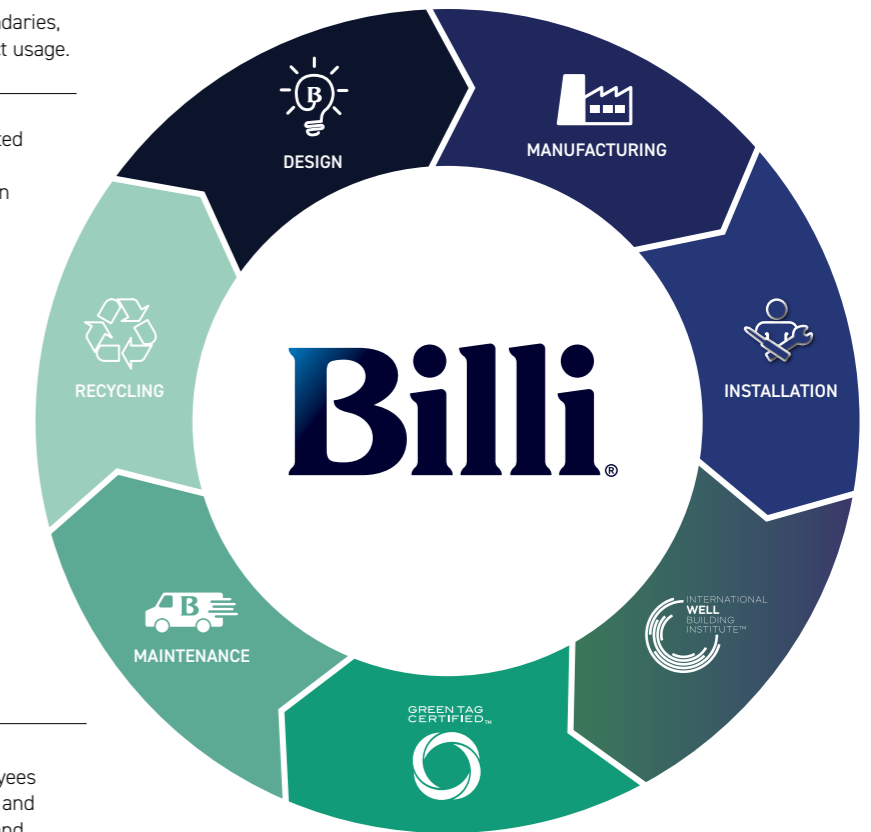



Billi®

ADVANCED
MULTI-STAGE
FILTRATION
TECHNOLOGY

Billi prides itself on offering world class water filtration products and continues to partner with global leading experts in all areas of water filtration.

- Activated carbon fibre
- High level chlorine & chemical adsorption
- Turbidity reduction
- Chemical taste & odour reduction
- Graded density structure to remove cysts with low pressure drop (994052 only)

Billi & BWT

Billi has partnered with BWT to provide the highest quality filters. BWT is Europe's largest water treatment products company.

Billi's range of premium filters utilise BWT's unique Fibron X technology. Fibron X technology has a graded density profile ensuring maximum performance and capacity. Billi's filter range provides superior water quality, consistent filter life and peace of mind.

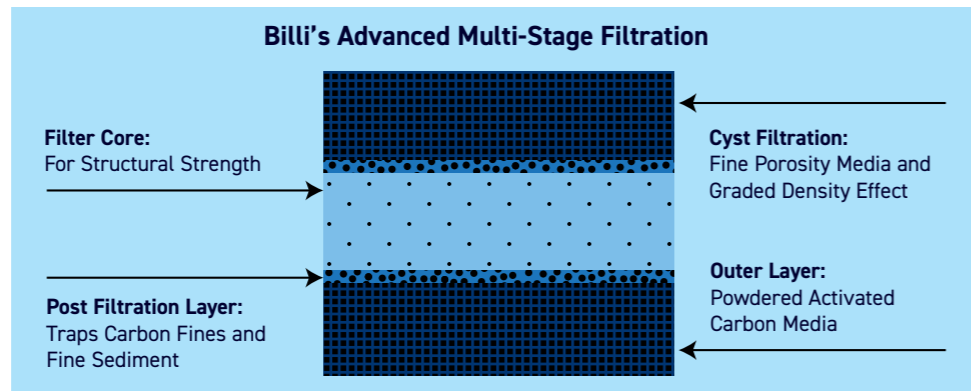

Billi Premium Filtration vs Standard Filtration

BWT FIBRON X CARBON FILTER

Fibron X technology uses activated carbon fibre with minimal bonding agent in a graded density profile. Fibron X media has a superior contaminant reduction performance and capacity.

STANDARD

CONVENTIONAL CARBON FILTER

Conventional filters are made up of granules and often held together with a resin, decreasing the surface area and therefore the quality of the filtration.

SEDIMENT
Filters out particles in the water

CHEMICALS
Reduces Chlorine and organic chemicals

MINERALS
Enables minerals to flow through the appliance without allowing scale build up

CYSTS
Removes parasitic cysts giardia and cryptosporidium (994052 & 994060 only)

LEAD
Reduces Lead and heavy metals (994052 only*)

Billi filters have been independently tested and certified by IAPMO to international standards and Australian Watermark. Billi filter performance testing is conducted in accordance with international standards NSF, WRAS and Watermark.

*Lead Reduction on 994052 @ 98.93%

Replacement Filters

Periodic replacement of filters is necessary to maintain water quality. Genuine replacement Billi filters are available on our website and from your local approved supplier. Filters are also available to suit the needs of different water supply areas.

Billi recommends you change your filter at least 12 months. However, close attention should be paid to local water conditions as it may be much sooner.

All Billi genuine filters come with Hygiene Protection Protocols. These protocols are designed to protect the end user from cross-contamination, while concurrently supporting the optimal function of your Billi product.

For further installation instructions refer to your user guide or visit our website. [EXPLORE MORE](#) Search: [Billi How to](#)



5 Micron Fibron X® Replacement Filter 994051

Nominal Filter Rating | 5 Micron
Filtration Capability | Sediment, Chlorine, Taste & Odour
Flow Rate | 3.8lpm
Water Pressure | 80 kPa min - 860 kPa max
Capacity | 30,000 litres (Chlorine reduction)
Water Temperature | 38°C max; Must not freeze

0.2 Micron Fibron XC® Replacement Filter 994052

Nominal Filter Rating | 0.2 Micron
Filtration Capability | Sediment, Chlorine, Taste & Odour
Parasitic Cysts, Lead
Flow Rate | 3.8lpm
Water Pressure | 80 kPa min - 860 kPa max
Capacity | 30,000 litres (Chlorine reduction)
Water Temperature | 38°C max; Must not freeze

HSD Fibron XT® Replacement Filter 994054

Filtration Capability | Sediment, Chlorine, Taste & Odour
Flow Rate | 3.8lpm
Water Pressure | 80 kPa min - 860 kPa max
Capacity | 30,000 litres (Chlorine reduction)
Water Temperature | 38°C max; Must not freeze

Sediment Only Replacement Filter 994056

Filtration Capability | Sediment
Flow Rate | 3.8lpm
Water Pressure | 80 kPa min - 860 kPa max
Capacity | 30,000 litres
Water Temperature | 38°C max; Must not freeze

0.2 Micron HF Sediment Only Replacement Filter 994060

Filtration Capability | 0.2 Micron HF Sediment
Flow Rate | 3.8lpm
Water Pressure | 80 kPa min - 860 kPa max
Capacity | 10,000 litres
Water Temperature | 38°C max; Must not freeze

We're proud to announce a major milestone.

Billi has produced our **500,000th** cartridge in September 2024! This achievement is a testament of dedication with our loyal partner **BWT**.



Case Study 1: Our Hydration Solutions for Healthcare Hubs

Project Overview

Billi's latest installation was in Murdoch Square, a sprawling 1.2-hectare, \$450 million development in Western Australia. It's a multi-faceted complex, housing the state's first purpose-built Medihotel, a Courtyard by Marriott hotel, a private hospital, an aged care facility, and a range of commercial and retail spaces. This ambitious project aims to significantly contribute to the government's vision of transforming the area into a specialised health precinct.

The Challenge: Adding Functionality and Aesthetics in a Healthcare Project

Perfect Practice Designer – Darcy Miller, that specialises in development projects like this, was tasked with creating a functional interior design within Murdoch Square. The waiting area, a crucial point of contact for patients and visitors, required a solution that could meet the demands of a high-traffic area while maintaining a calm and sophisticated ambiance.

The Solution: Billi Alpine 125 with Matte White XL and Matching Font & Riser

The Billi Alpine 125 under-bench system, paired with the elegant Matte White XL tap and matching Matte White font & riser setup, was a perfect fit for the existing cabinetry design.



The Results and Benefits: (Functions, Safety & Health)

- **Safe Integration:** The Alpine 125's compact design allowed for discreet installation, preserving valuable space and maintaining the clean lines of joinery. The Matte White XL tap and font/riser, with its understated elegance, seamlessly blends with the modern aesthetic of the space.
- **Hydration Station:** The system provides instant access to filtered chilled water, catering to the hydration needs of patients, visitors, and staff. The controls and intuitive interface ensured ease of use for all.
- **Hygiene Protection Protocol:** In a healthcare environment, hygiene is paramount. Billi's advanced filtration technology ensures the delivery of clean, safe drinking water, while the riser minimizes the risk of cross-contamination.
- **Wheelchair Accessible:** The Billi font allows for custom installation and easy wheelchair-user access.



Additional References for Architects & Interior Designers:

We have learnt to tailor solutions to the different level of needs that Healthcare and other buildings belong to, under the classifications of the [National Construction Code](#).



Class 1

Domestic or residential buildings – single, standalone single houses and horizontally attached houses, such as terrace houses, row houses or townhouses. This class includes two sub-classifications:

- Class 1a – a single dwelling or one of a group of attached dwellings, e.g. a terrace house
- Class 1b – a boarding house, guest house or hostel with a floor area less than 300 m2.



Class 5

Office buildings for professional and/or commercial purposes, such as offices for government agencies, accountants or lawyers.



Class 9

Public buildings – includes three sub-classifications:

- Class 9a – healthcare buildings such as hospitals and day surgery clinics
- Class 9b – buildings where people assemble for social, political, theatrical, religious or civic purposes, e.g. schools, universities, sports facilities, night clubs
- Class 9c – aged care facilities.

At Billi we understand the important duty of planning a functional living or work environment, and we strive to meet not only the basic standards, but also go beyond to help our clients in specification stay "up to code" too.

References:

[Building Classifications](#)
[National Construction Code](#)

Visit our website

EXPLORE MORE 
Search: Billi SPEC or Billi 3D Build

Select your preferred instant filtered water system by choosing the ideal combination to suit your requirements



Decide on the number of people that will be using the instant filtered water system

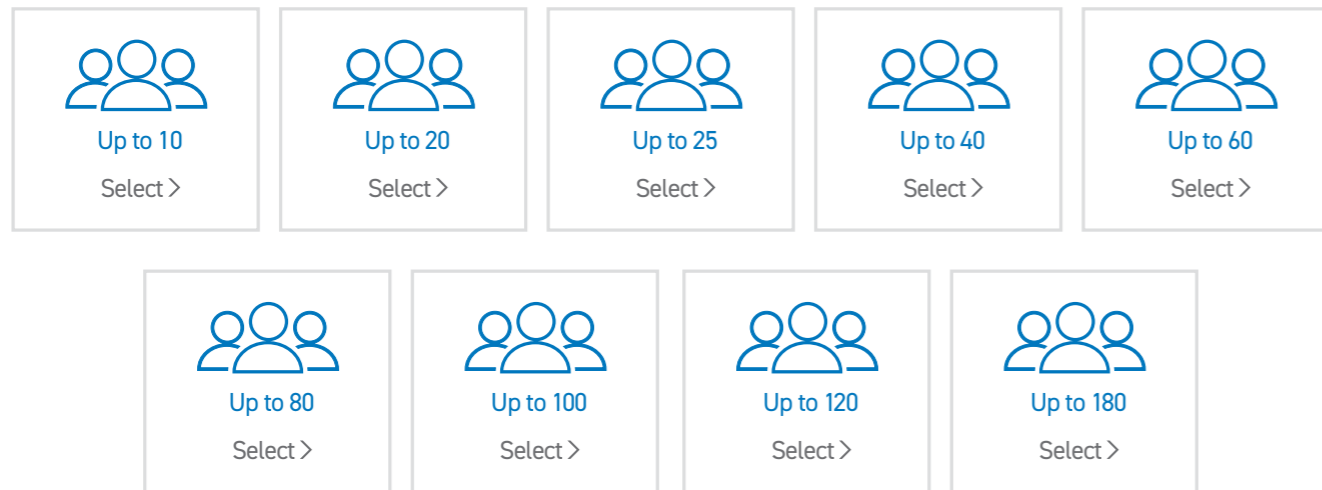

Select your preferred dispenser design from the compatible options



Optional Add Ons

Would you like a PLUS unit with separate sink mixer to provide hot & cold water?
Select your preferred mixer tap option



Need to install away from a sink? Use our range of fonts and risers to ensure the dispenser is optimally positioned

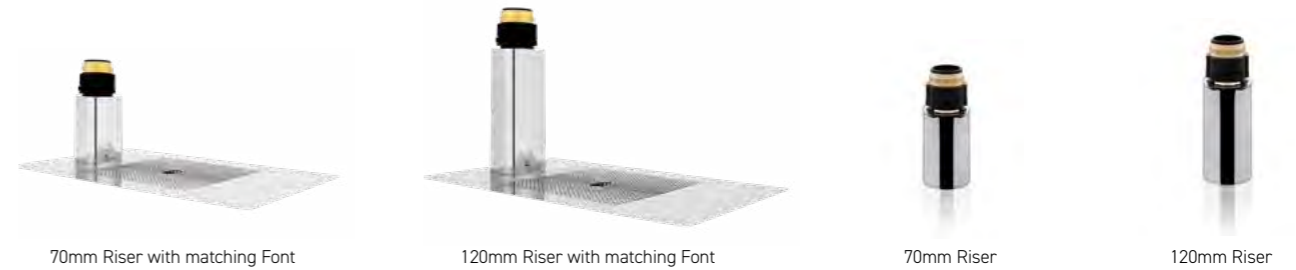

Select a specialty dispenser for additional safety in critical care environments



We're more than filtered water systems

Sensor Taps



Sensor Soap Dispensers



On Wall Boiling Water



Billi Ultra On Wall Boiling Water Unit



flow MEETS FUNCTION

The Billi Multifunction Mixer Tap is a testament to our commitment towards innovation and excellence, we've created a perfect filtered water system that is both functionally versatile and aesthetically elegant for any modern kitchen.

Recognised by Good Design Australia awards, our Multifunction Mixer Tap exemplifies the perfect blend of state-of-the-art filtration with under-bench technology, making it one seamless solution where 'Flow meets Function'.



ELEVATED TAP ARCH

Elevate your kitchen with an increased height clearance of 260mm, with 180° degrees of arch rotation.

OPTIMISED SPOUT TIP

Over 2 years of innovation and rigorous testing to ensure optimal user experience.

SPACE SAVING

2 fixtures in 1 that offer a worry-free classic installation or a seamless retrofit, increasing valuable counterspace.

AWARDED BY EXPERTS

Critiqued and recognised by a panel of global design experts as a solution to satisfy density reform in residential developments & flexible workspaces.



All in One Multifunction Mixer Tap. Seamlessly Integrated User Interface.

ONE 5 in 1 FUNCTIONALITY

One multifunctional fixture to match Billi's range of instant filtered boiling, chilled, sparkling and mains fed hot/cold water systems.

ERGONOMIC INTERFACE

Practical touch-sensor user interface placed on the side to reduce risks of scalding, splashing, and accidental dispense.

SMART SAFETY

"Red for no, green for go." Smart locking tech with visual safety and fault indicators, in line with Billi's protection protocols.

AUSTRALIAN DESIGNED & MADE

Compliant to Watermark with a 5-Star WELS rating to meet & exceed ANZ Standards.





Have it All, in One.

MULTIFUNCTION FILTERED DRINKING WATER APPLIANCE

Billi's new OmniOne range is the latest iteration of multifunction filtered drinking water appliances.

The intersection of genuine innovation and sustainable design, OmniOne integrates Billi's renowned water-cooling and energy reclaim technologies into single space-saving under bench control module.

With a 30% uplift in performance, whisper quiet in operation, ergonomic and acutely focused on the wellness & hygiene of it's users, the OmniOne range is the ultimate inclusion to the modern workplace or facility.

OmniOne Pro60 supersedes the **Quadra Sparkling 460**.
OmniOne Plus 9 supersedes the **Quadra Sparkling Plus+ 9**.

CHOICE OF DISPENSER DESIGNS

Sleek compatibility. Multifunction appliance compatible with all Billi tapware styles, ranging from boiling to chilled, and sparkling to still.

SPACE SAVING

40% less clearance clearance required than comparable models. High on spec, but small on space.

NO AIR VENTS NEEDED

Cross ventilation not required, no unsightly joinery cutouts or costly accessories.

INTUITIVE CONTROLS

Intuitive controls. Easy time, temp & safety settings; with energy-saving, override and locked-off modes.



SUPERIOR PERFORMANCE

30% more capacity and more consistent delivery of cold water than than any previous model.

SILENT DESIGN

Whisper quiet! 70% dB noise reduction during normal operation, eliminating noisy interruptions.

HEAT EXCHANGE TECHNOLOGY

Reduce energy waste with Billi's world-leading water-cooled and heat energy reclaim tech.

SMART SAFETY

Billi's protection protocols guard against cross contamination, and mitigates risks of Legionella.

*comparable models refers to Billi's previous BCS platform.





Urban Brass XL Levered Dispenser with matching Round Gooseneck Mixer Tap



Billi Eco

Instant boiling and chilled filtered water system

FEATURES



DISPENSER OPTIONS



Product Code	Model	Suggested no. of people	Boiling water delivery (cups per hour)*	Chilled water delivery (cups per hour)	Power supply (amps)
901000	Eco	up to 10	90	60	10



Billi Eco Sparkling

Instant boiling, chilled and sparkling filtered water system

FEATURES



DISPENSER OPTIONS

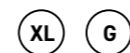

Product Code	Model	Suggested no. of people	Boiling water delivery (cups per hour)*	Chilled and Sparkling (cups per hour)	Power supply (amps)
906000	Eco Sparkling	Up to 10	90	100	2 x 10

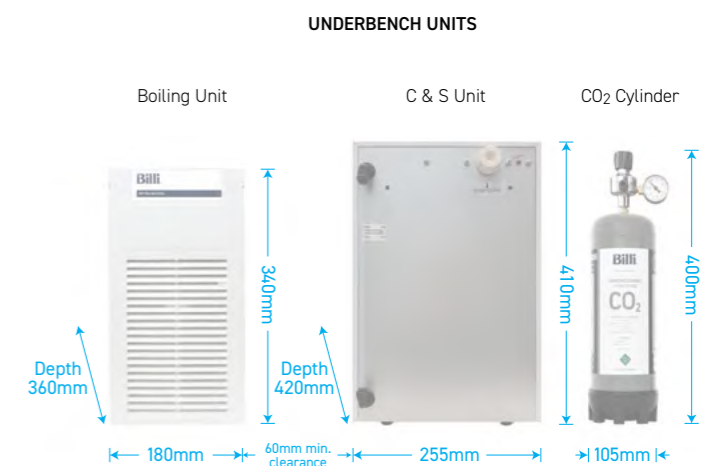

* Based on a set volume of water being drawn every 30 seconds at an inlet temperature of average temperature 21°C. Each cup is equivalent to 170ml. Usage patterns and draw-off methods can impact recovery.



Billi Quadra

Instant boiling and chilled filtered water system

FEATURES



DISPENSER OPTIONS



Product Code	Model	Suggested no. of people	Boiling water delivery (cups per hour)*	Chilled water delivery (cups per hour)	Power supply (amps)
904010	Quadra Compact	up to 20	100	150	10
904020	Quadra 420	up to 25	120	175	10
904040	Quadra 440	up to 40	150	175	10
904060	Quadra 460	up to 60	180	175	10
904100	Quadra 4100	up to 100	250	175	15
904180	Quadra 4180	up to 180	350	175	20

^ XT not available with Quadra Compact and Quadra 460.

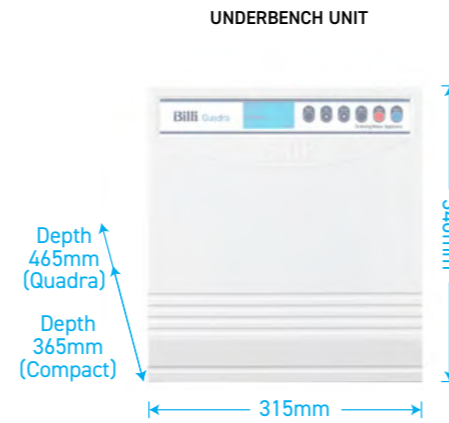

Billi Quadra Plus

Instant boiling and chilled filtered water system plus hot and cold mixer tap.

FEATURES



DISPENSER OPTIONS + MIXER TAP OPTIONS



Product Code	Model	50° hot water capacity litres (initial drawdown)	50° hot water delivery litres per hour	Boiling water delivery (cups per hour)*	Chilled water delivery (cups per hour)	Power supply (amps)
904025	Quadra Plus 5	7	40	120	175	10
904065	Quadra Plus 9	9	60	180	175	10
904105	Quadra Plus 15	15	85	250	175	15

* Based on a set volume of water being drawn every 30 seconds at an inlet temperature of average temperature 21°C. Each cup is equivalent to 170ml. Usage patterns and draw-off methods can impact recovery.



Billi Quadra Sparkling

Instant boiling, chilled and sparkling filtered water system.

FEATURES



DISPENSER OPTIONS



Product Code	Model	Suggested no. of people	Boiling water delivery (cups per hour)*	Chilled & Sparkling water delivery (cups per hour)	Power supply (amps)
906100	Quadra Sparkling 4100	100	Up to 220	200	1 x 10 1 x 15

906060 Quadra Sparkling 460 has been superseded by the new model, 926060 OmniOne Pro60.

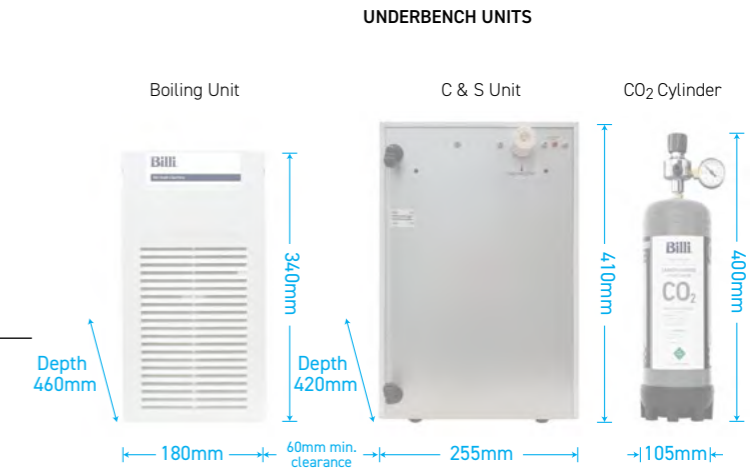

Billi Quadra Sparkling Plus

Instant boiling, chilled and sparkling filtered water system plus separate hot and cold mixer tap.

FEATURES



DISPENSER OPTIONS + MIXER TAP OPTIONS



Product Code	Model	50° hot water capacity litres (initial drawdown)	50° hot water delivery litres per hour	Boiling water delivery (cups per hour)*	Chilled & Sparkling water delivery (cups per hour)	Power supply (amps)
906105	Quadra Sparkling Plus 15	15	85	Up to 220	200	1 x 10 1 x 15

906065 Quadra Sparkling Plus 9 has been superseded by the new model, 926065 OmniOne Plus 9.

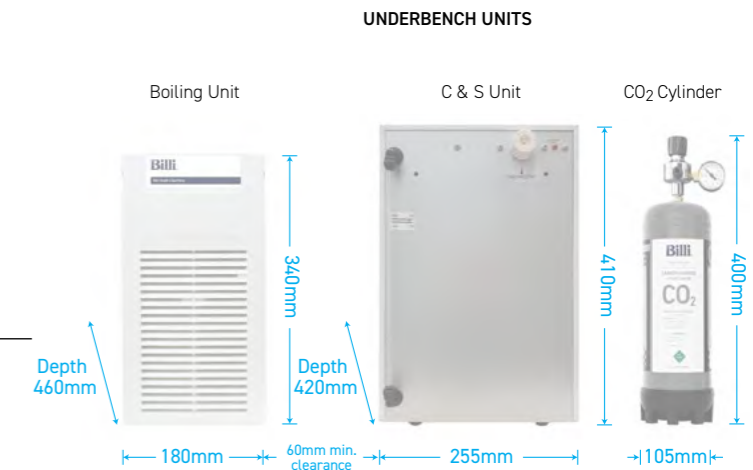



Billi OmniOne

The Billi OmniOne is the latest iteration of multifunction filtered drinking water appliances.

FEATURES



DISPENSER OPTION



Product Code	Model	Dispenser/Mixer Tap	Suggested no. of people	Boiling water delivery (cups per hour)*	Chilled & Sparkling water delivery (cups per hour)	Power supply (amps)
926060L	OmniOne Pro60	XL	Up to 60	180	220	1 x 10

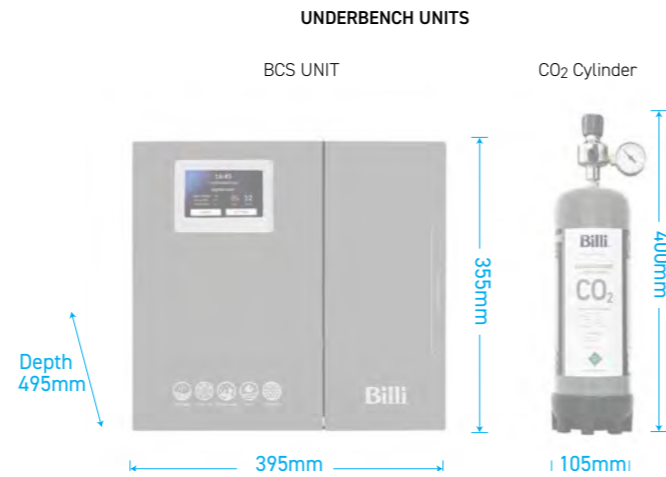

Billi Sahara

Instant boiling and still filtered water systems

FEATURES



DISPENSER OPTIONS



Product Code	Model	Suggested no. of people	Boiling water delivery (cups per hour)*	Still water delivery (cups per hour)	Power supply (amps)
943010	Sahara 310	up to 10	90	unlimited	10
943020	Sahara 320	up to 25	120	unlimited	10
943060	Sahara 360	up to 60	165	unlimited	10
943120	Sahara 3120	up to 120	220	unlimited	15

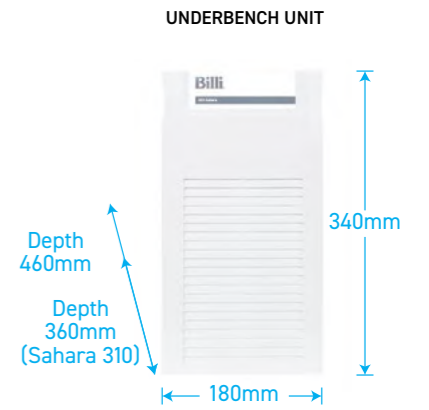

Billi OmniOne Plus

The Billi OmniOne Plus 9 is the latest iteration of multifunction filtered drinking water appliances.

FEATURES



DISPENSER OPTION + MIXER TAP OPTIONS



Product Code	Model	Suggested no. of people	50° hot water delivery litres per hour	Boiling water delivery (cups per hour)*	Chilled & Sparkling water delivery (cups per hour)	Power supply (amps)
926065LP	OmniOnePlus 9	Up to 60	60	180	220	1 x 10
926065LG	OmniOnePlus 9	Up to 60	60	180	220	1 x 10
926065LS	OmniOnePlus 9	Up to 60	60	180	220	1 x 10

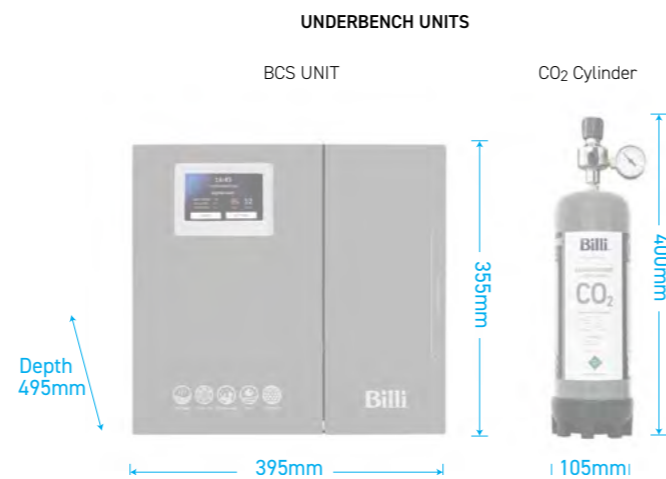

Billi Sahara Plus

Instant boiling and still filtered water system plus separate hot and cold mixer tap.

FEATURES



DISPENSER OPTIONS + MIXER TAP OPTIONS



Product Code	Model	50° hot water capacity litres	50° hot water delivery litres per hour	Boiling water delivery (cups per hour)*	Still water delivery (cups per hour)	Power supply (amps)
943025	Sahara Plus 320	7	25	120	unlimited	10
943065	Sahara Plus 360	9	40	165	unlimited	10
943125	Sahara Plus 3120	15	65	220	unlimited	15



A reserve of boiling water is still available after hot water is fully drawn.

* Based on a set volume of water being drawn every 30 seconds at an inlet temperature of average temperature 21°C. Each cup is equivalent to 170ml. Usage patterns and draw-off methods can impact recovery.



Billi Alpine

Chilled and still filtered water systems

FEATURES



DISPENSER OPTIONS

Alpine 060/120: **R** **S** **E** Alpine 125: **XL** **XT** **XR** **G**

Product Code	Model	Product feature	Suggested no. of people	Chilled delivery (cups per hour)	Power supply (amps)
932060	Alpine 060	Chilled	12	60	10
932120	Alpine 120	Chilled	25	120	10
932125	Alpine 125	Chilled & Still	40	120	10



Billi Filter Tap

Instant still filtered water system

FEATURES



DISPENSER OPTIONS

R **S** **E**

Product Code	Model	Still water cups per hour
932210	Filter Tap	unlimited



Billi Alpine Sparkling

Professional grade chilled & sparkling system

FEATURES



DISPENSER OPTIONS

D

Product Code	Model	Suggested no. of people	Chilled & Sparkling delivery (cups per hour)	Power supply (amps)
933100	Alpine Sparkling 100	40	100	10
933200	Alpine Sparkling 200	80	200	10

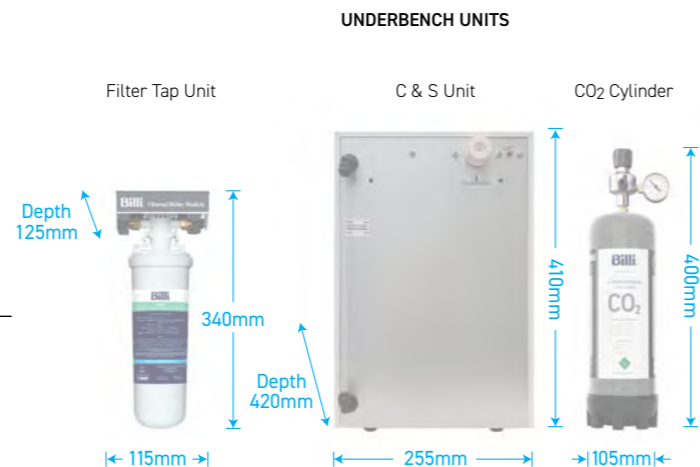

Urban Brass XL Levered Dispenser with matching Round Gooseneck Mixer Tap

X SERIES DISPENSERS



XL Levered Dispenser (XL)

Our Commercial Flagship and still a classic, the levered dispenser is streamlined and elegant. It is simply operated with position-sensitive levers.

Add 'L' and finish code to product code (901000LCH)

AVAILABLE FINISHES

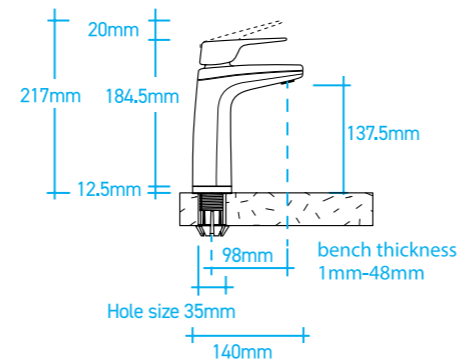
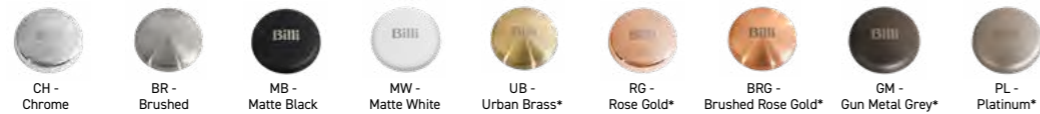

XT Touch Dispenser (XT)

The touch dispenser is an innovative, contemporary design, which has a top operating panel offering a sophisticated and clean style.

Add 'T' and finish code to product code (901000TCH)

AVAILABLE FINISHES

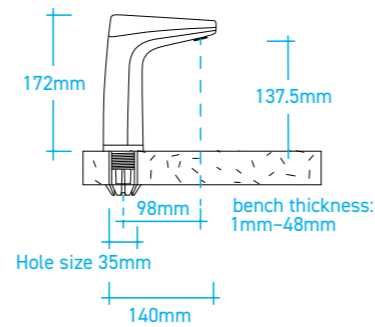

XR Remote Dispenser (XR)

The remote dispenser is another version of the lever free dispenser, however the operation panel is located away from the dispenser. This can be installed in your desired position to meet design requirements, particularly wheelchair access.

Add 'R' and finish code to product code (901000RCH)

AVAILABLE FINISH

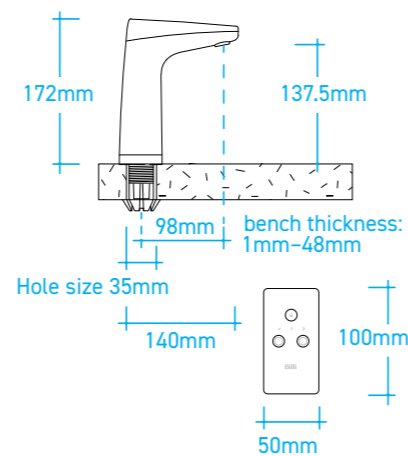

MULTIFUNCTION MIXER & SPECIALTY DISPENSERS



Multifunction Mixer Tap (G)

Award winning multifunction dispenser capable of dispensing filtered drinking water and domestic water for the sink from a single fixture. Requires Hot & Cold mains connection.

Add 'G' and finish code to product code (926060GCH)

AVAILABLE FINISHES

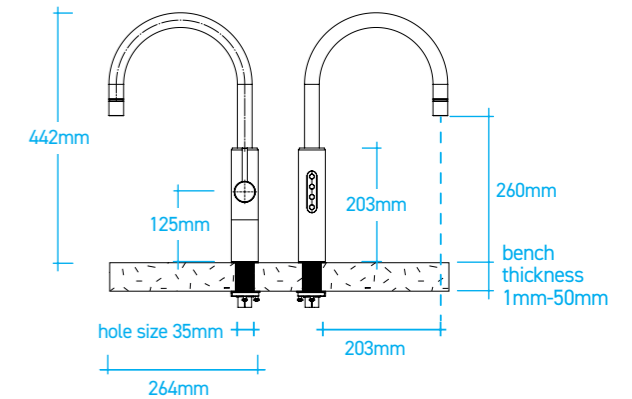

Safety Dispenser (SD)

Safety Dispenser has been specifically designed as a solution for critical care applications, such as correctional centres, mental health facilities and aged care.

Add 'V' and finish code to product code (901000VCH)

AVAILABLE FINISH

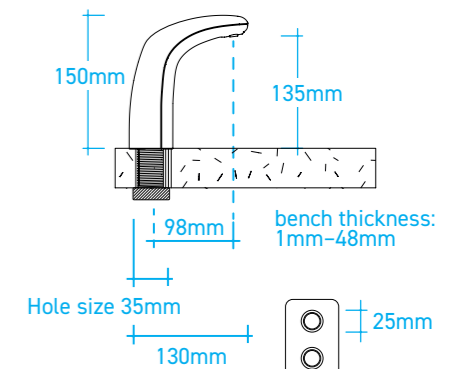

Coloured XL Levered Dispenser

Special order coloured levers provide full vision safety where LED indicators cannot be seen.

Spare Parts Code: 996300
Add 'LRB' to the product code (901000LRB)

BRAILLE PADS

Optional braille pads can be supplied with the coloured XL levered dispenser to provide further safety for vision impaired users.

AVAILABLE FINISH

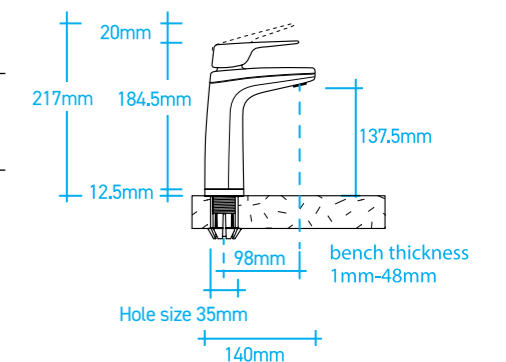

Dispenser finishes

Our dispensers come in a variety of modern and stylist finishes to match your kitchen environment. There are 4 standard finishes and 5 special order finishes, that may incur longer lead times, to choose from.

Standard finishes



Special order finishes



*Refer to individual specification for available finish range by product variant



Dual Lever Dispenser **(D)**

Round in design with dual levers. Suitable for chilled and sparkling water.

Add 'D' and finish code to product code (933100DCH)

AVAILABLE FINISHES

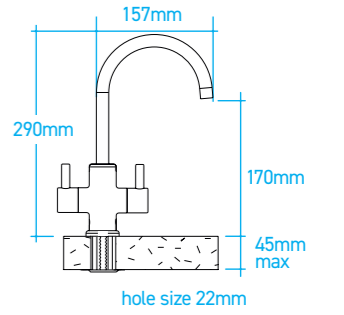
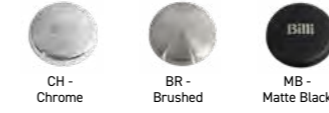

Round Slimline Dispenser **(R)**

Round in design with single pin lever option. Suitable for ambient or chilled water.

Add 'R' and finish code to product code (932060RCH)

AVAILABLE FINISHES

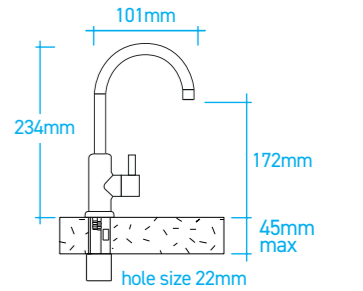
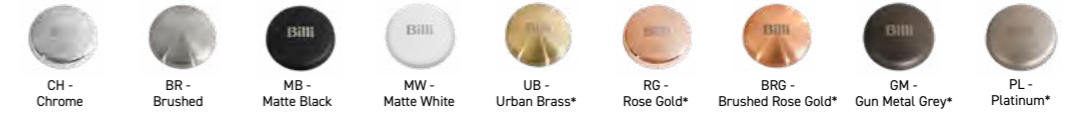

Square Slimline Dispenser **(S)**

Square in design with single paddle lever option. Suitable for ambient or chilled water.

Add 'S' and finish code to product code (932060SCH)

AVAILABLE FINISHES

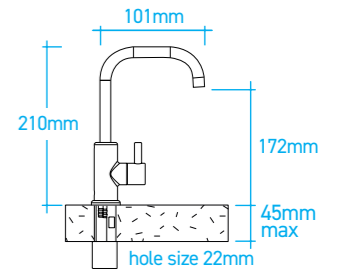
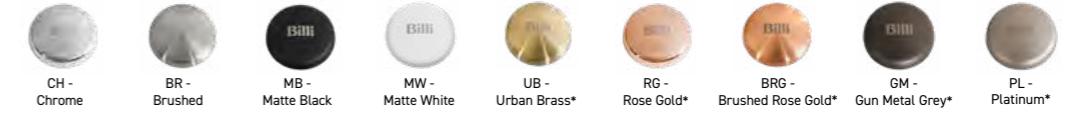

Slimline Dispenser Accessory



Square Slimline Spout Extension **(E)**

Extended spout allows bottles and jugs to be filled when the tap is installed on a front.

Add 'E' and finish code to product code (932060ECH)

AVAILABLE FINISHES

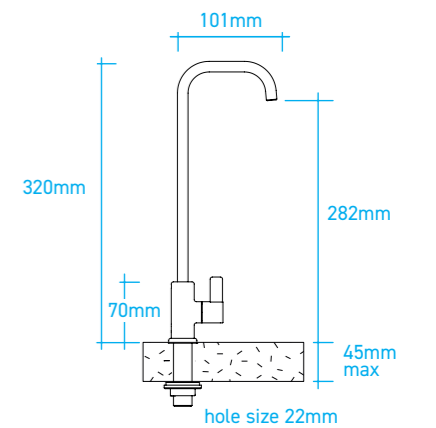
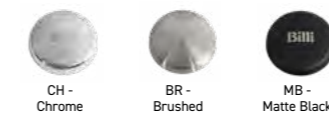

* Special Order Finishes

MIXER TAPWARE



Gooseneck Mixer Tap G PLUS

Round gooseneck design suitable for plus units and offers hot and cold water in addition to X Series dispenser range. Also available as a stand-alone mixer tap.

Add 'G' and finish code to product code and dispenser option (904025LGCH)

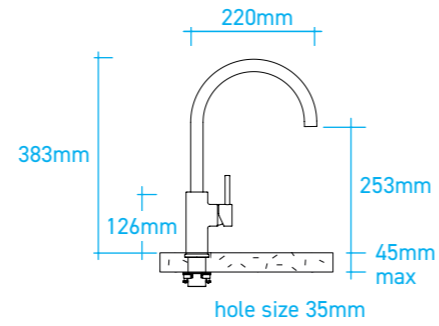

AVAILABLE FINISHES

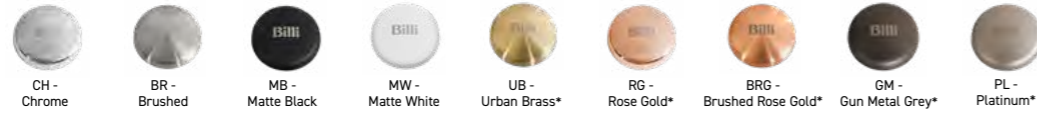

Square Mixer Tap S PLUS

Square gooseneck design suitable for plus units and offers hot and cold water in addition to X Series dispenser range. Also available as a stand-alone mixer tap.

Add 'S' and finish code to product code and dispenser option (904025LSCH)

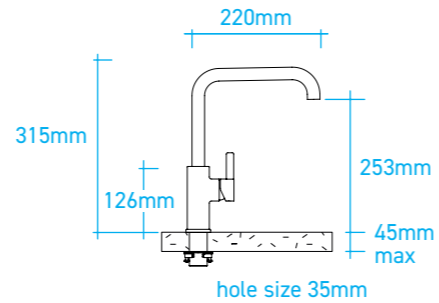

AVAILABLE FINISHES

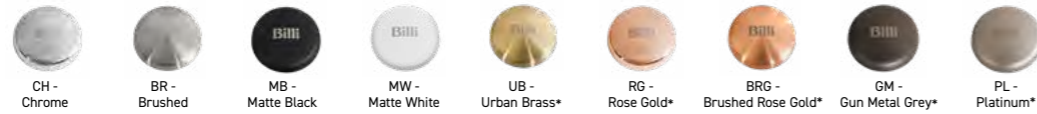

Paddle Lever Mixer Tap P PLUS

Standard mixer tap supplied with Plus units and offers hot and cold water in addition to X Series dispenser range. Also available as a stand-alone mixer tap

Add 'P' and finish code to product code and dispenser option (904025LPCH)

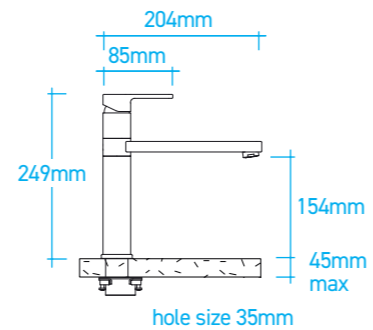

AVAILABLE FINISHES

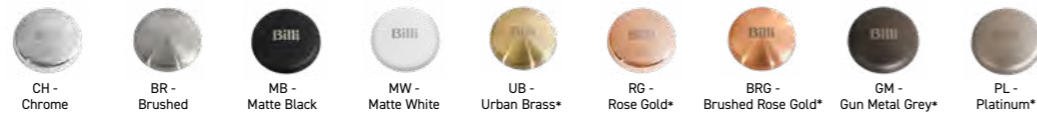

Mixer Tap Accessory



Disabled Lever - For use with Paddle Lever Mixer Tap

Suitable for plus units and offers hot and cold water in addition to X Series dispenser range.

Product Code : 992121CH / 992121MB

AVAILABLE FINISHES

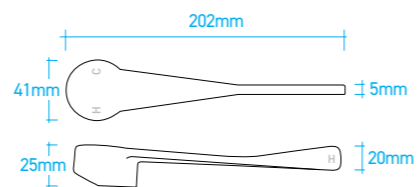

* Special Order Finishes

BILLI MOBILE INNOVATION



Billi's **3D Build** is the latest mobile innovation. The online tool allows you to specify and shop our products in a few simple clicks.

Use the 3D build to visualise how a Billi system would look in your commercial or residential kitchen.

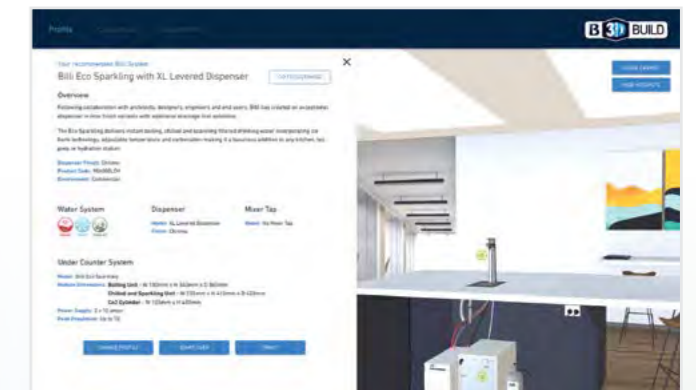

We're pleased to continue to innovate for Specifiers with access to TWO specification & documentation portals.

- 3D Build provides you with a guided specification resource that simulates your selection into a staged environment while providing all of your documentation requirements.
- The BSPEC Generator also provides guided specification support, generating key documentation and basic images for download.



ACCESSORIES

Font with 70mm Riser

Suitable for: **(XL)** **(XT)** **(XR)**

Product Code: 992800

AVAILABLE FINISHES

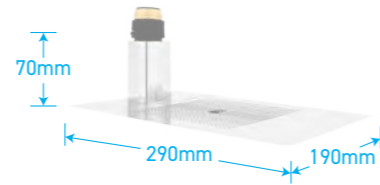

*Special order finishes are available. Special orders only.

Font with 120mm Riser

Suitable for: **(XL)** **(XT)** **(XR)**

Product Code: 992803

AVAILABLE FINISHES

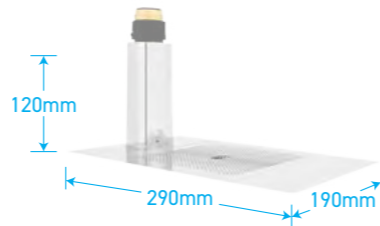

*Special order finishes are available. Special orders only.

Slimline Font

Suitable for: **(R)** **(S)** **(E)** **(D)**

Product Code: 992810

AVAILABLE FINISHES

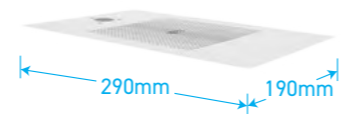
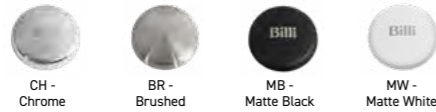

*Special order finishes are available. Special orders only.

70mm Riser

Suitable for: **(XL)** **(XT)** **(XR)**

Product Code: 992820

AVAILABLE FINISHES



*Special order finishes are available. Special orders only.

120mm Riser

Suitable for: **(XL)** **(XT)** **(XR)**

Product Code: 992830

AVAILABLE FINISHES



*Special order finishes are available. Special orders only.



Tubing Extension Kit for X series dual temp dispensers - 2mtrs

Suitable for: **(XL)** **(XT)** **(XR)** **(G)**

Product Code: 990720

1mtr version also available, Product Code: 990712



Tubing Extension Kit for Plus units - 1.8mtrs

Suitable for: **(P)** **(G)** **(S)**

Product Code: 990714



Tubing Extension Kit for Slimline Tap - 2mtrs

Suitable for: **(R)** **(S)** **(E)**

Product code: 990724



Tubing Extension Kit for Sparkling units - 2mtrs

Suitable for: **(XL)** **(G)**

Product code: 990726



Tubing Extension Kit for Slimline Sparkling units - 2mtrs

Suitable for: **(D)**

Product code: 990727



CO2 Cylinder

Suitable for: All Billi Underbench Sparkling Units

Product Codes: 996911 - Single (1.1kg)
996912 - 2 Pack (2 x 1.1kg)



SUSTAINABLE CO2

Refillable CO2 Cylinder Now Available

To see if refillable CO2 is available in your area or to arrange a refillable CO2 plan please contact Billi on 0800 636 0 636 or email us: service@billi.co.nz



BOILING

Billi Ultra

The Billi Ultra is a cost effective source of instant boiling water at the touch of a lever.

This wall mounted unit is ideal for commercial environments.

Ultra has a range of 5 capacities from 3L for small kitchenettes, through to 25L for high volume requirements such as sporting clubs, HoReCa venues or community centres.



* Ultra 2500 unit dimensions shown

Product Code	Model	Initial delivery capacity cups	Boiling water delivery (cups per hour)	Heating Element (kW)	Product dimensions H x W x H mm
910030	Ultra 300	20	170	2.4	370 x 260 x 155
910060	Ultra 600	38	188	2.4	420 x 310 x 170
910080	Ultra 800	50	200	2.4	510 x 310 x 170
910160	Ultra 1600	100	250	2.4	545 x 365 x 220
910250	Ultra 2500	160	310	2.4	550 x 414 x 264



CHILLED

RM 33 Bubblers

Delivering up to 30 litres of chilled water per hour, the RM Bubbler satisfies the hydration needs of demanding public & community environments such as schools, fitness centres & stadiums, factories & workshops more. Made from tough, durable materials, this bubbler is perfectly suited to outdoor areas and locations that are usually exposed to harsh weather and rough-use conditions.



FEATURES

- IP 33 Rating
- Capacity suitable for high volume areas
- 100% rust proof and UV stabilised cabinet to prevent material degradation
- Includes standard drinking spout and convenient bottle filler
- Impact resistant construction
- Strong built and dependable, ideal for outside environments
- Granite style finish

Product Code	Model	Capacity	Chilled water delivery glasses per hour	Power supply (amps)
988016	RM 33 Bubbler	30L/hour	175*	10

Water temperature at 5°C.

*Based on the initial number of glasses of chilled water immediately available, drawn one cup every 10 seconds.



Matte Black XL Dispenser with Matte Black Square Mixer Tap



Hands Free Sensor Taps

Billi's sensor tap range has a unique electronic sensor built into the spout which automatically detects hand movement in the hand washing zone and shuts off as soon as you move your hands away, reducing water wastage. Available in wall or bench mount options.

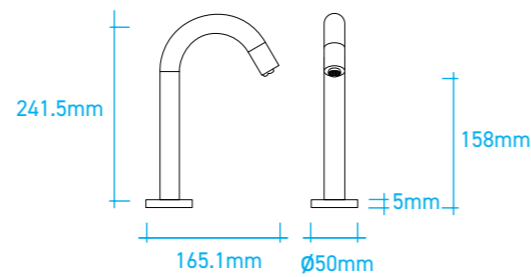

AVAILABLE FINISHES

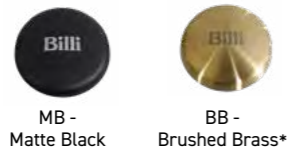

* Special Order Finishes

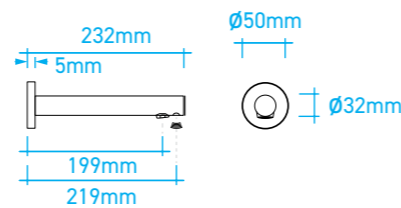
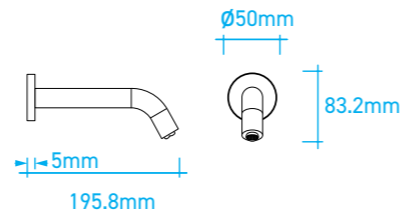

Hands Free Soap Dispensers

Offering a touchless handwashing experience, Billi's hands free soap dispensers featuring a 1000ml reservoir and battery or mains power supply. Available in wall or bench mount options.

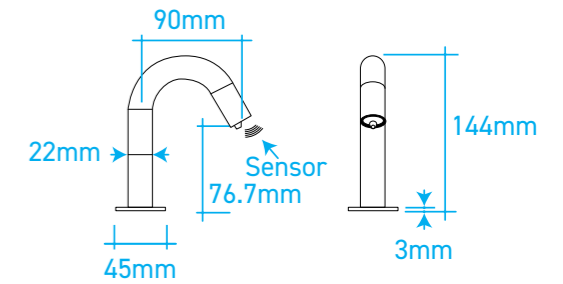

AVAILABLE FINISHES

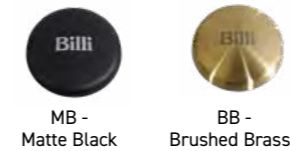

* Special Order Finishes

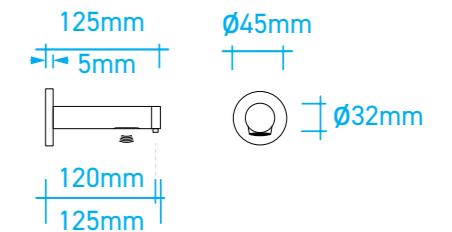
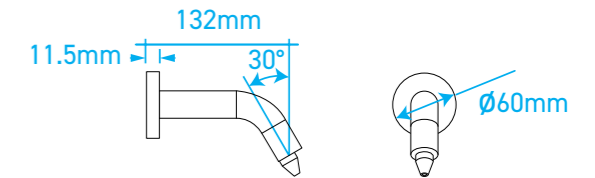

Product Code	Model	WELS rating	Flow rate
961000	Bench Mount Sensor Tap	6 Star	4 litres / min.
961100	Wall Mount Sensor Tap	6 Star	4 litres / min.
961300	Straight Wall Mount Sensor Tap	6 Star	4 litres / min.

Product Code	Model	Reservoir Size	Max. dispense time
982410	Bench Mount Sensor Soap Dispenser	1000ml	10 seconds
982411	Wall Mount Sensor Soap Dispenser	1000ml	10 seconds
982412	Straight Sensor Soap Dispenser	1000ml	10 seconds



Hands-free sensor tap wall mounted



Hands-free sensor tap straight wall mounted with accompanying straight wall soap dispensers

Underbench Units

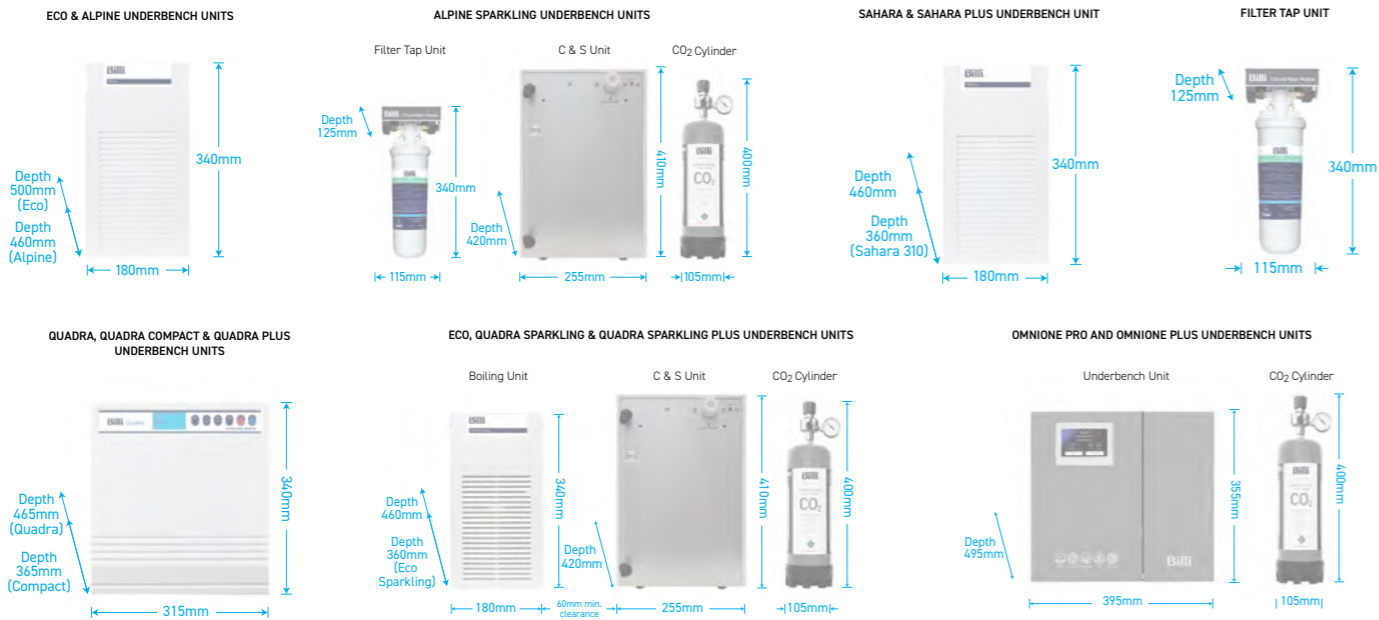

Dispensers

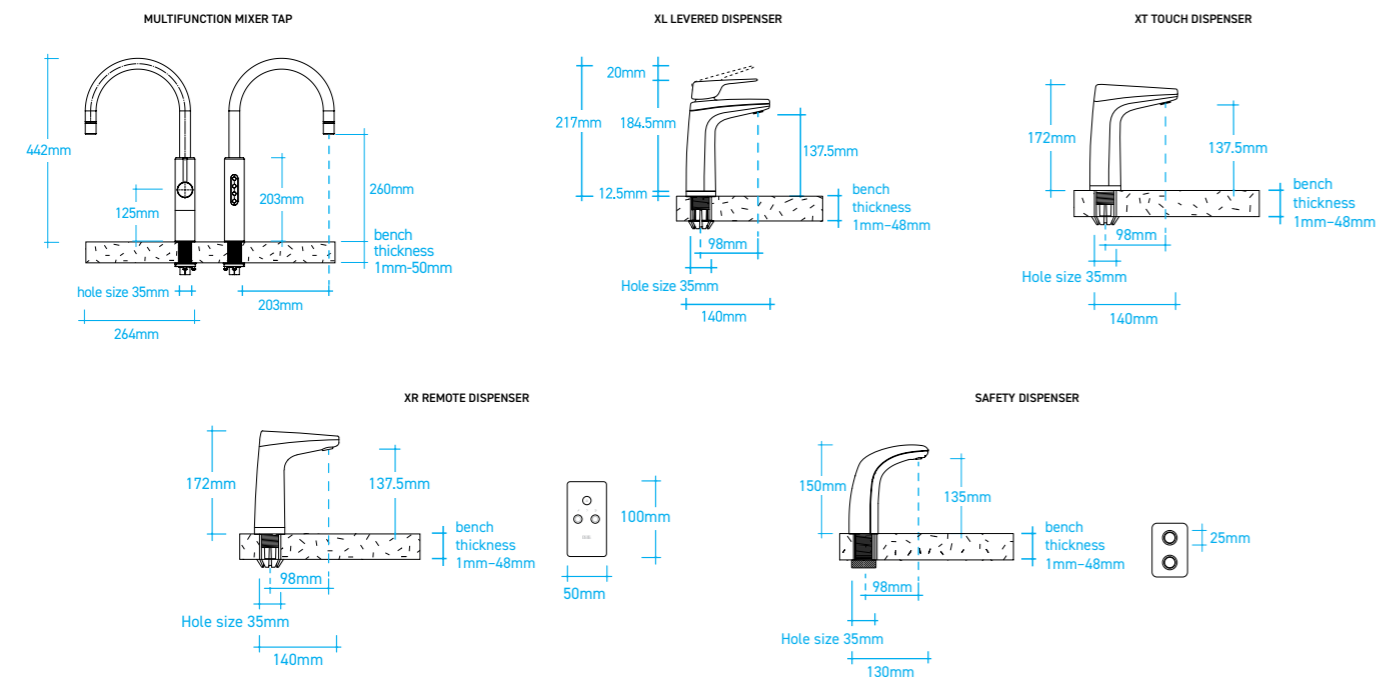

Slimline Dispensers

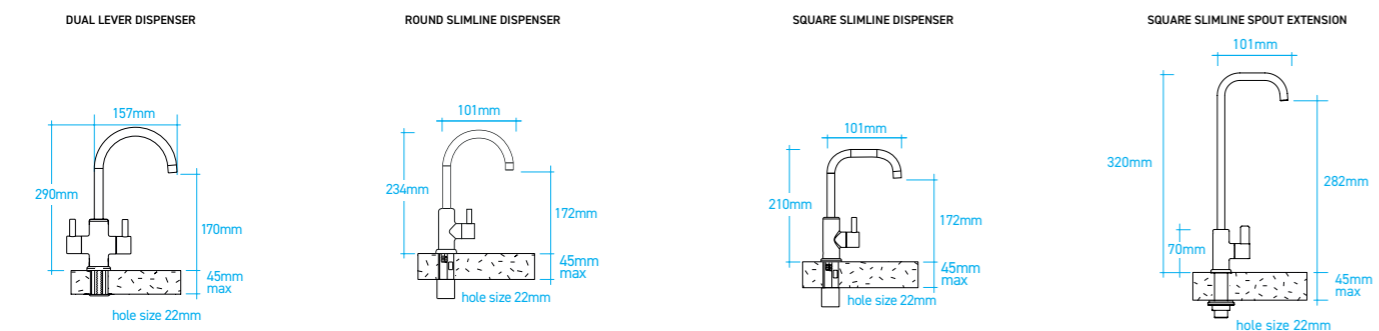

Mixer Taps

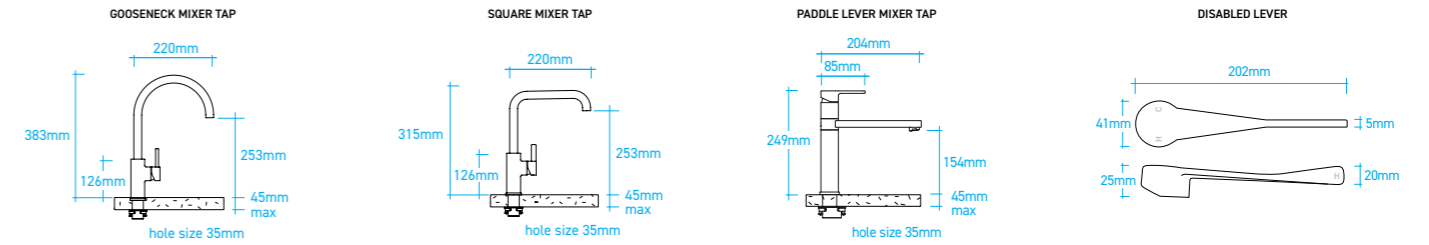

Accessories

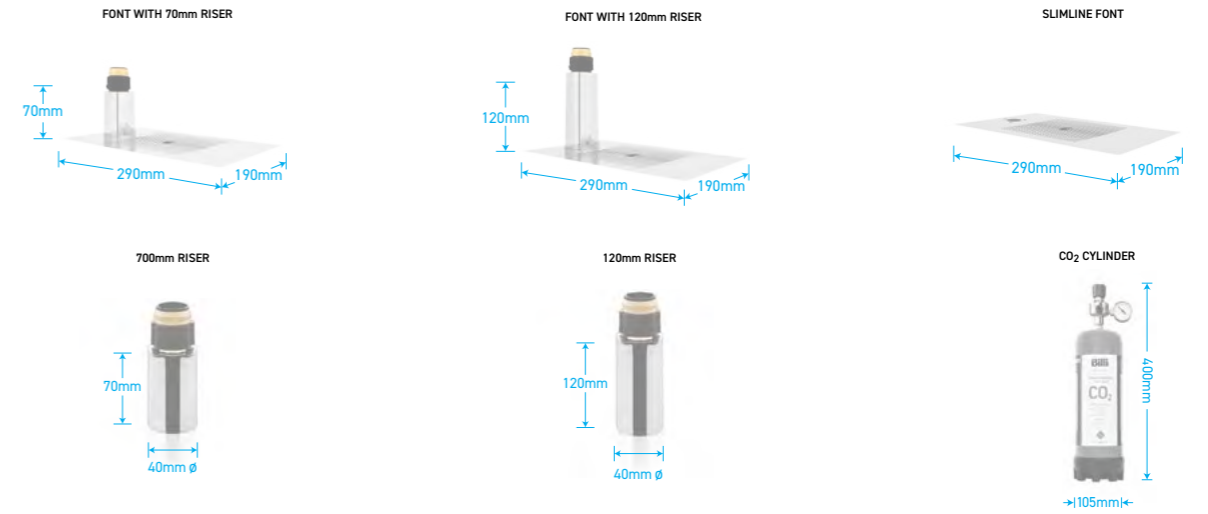

Hands Free Sensors

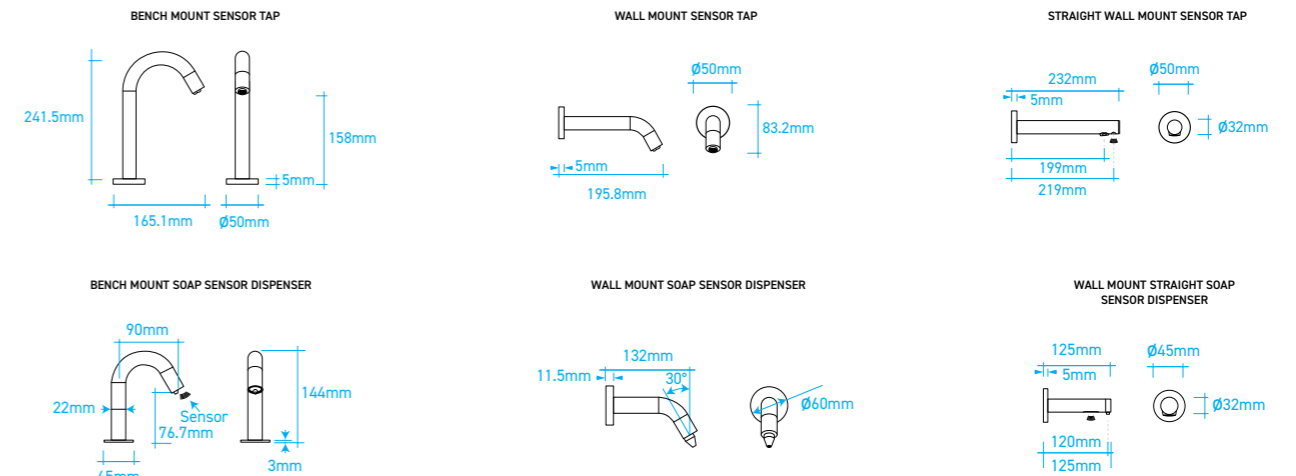

Others

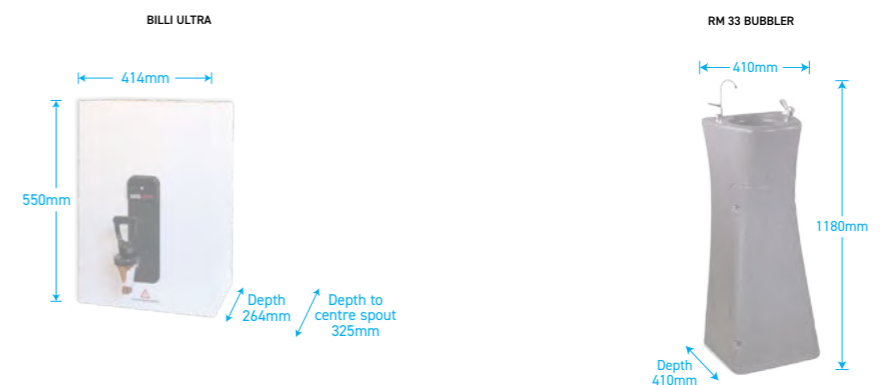



Quality
ISO 9001



*On Quadra and Quadra Plus models only.



Standard Warranty

All components of the drinking water systems are covered by a 24-month warranty. OmniOne products are covered under 36 month warranty. The washroom range is covered by a 12 month warranty.

Commitment to Quality

A strong commitment to quality is as important to Billi as style, function and innovation. Recognising the importance of reliability to customers, all Billi water systems are manufactured to strict quality standards.

Every system is designed to provide the highest possible standards of efficiency and energy savings.

Certifications

Every Billi drinking water appliance is manufactured under a certified quality control system. They have been tested and comply with all relevant standards.

Billi **Eco, Eco Sparkling, Quadra, Quadra Sparkling, Quadra Plus, Quadra Sparkling Plus, Billi Sahara and Sahara Plus** systems are tested to and comply with; Watermark license number WM-21525, AS/NZS3498.

Billi **Alpine** and **Filter Tap** systems are tested to and comply with; Watermark license number WM-21882, ATS 5200:105.

Billi **Multifunction Mixer Tapware** is tested and compliant to Watermark WM 021914.

BWT filter models 994051, 99052, 994054, 994056 & 994060 are tested to and comply with; Watermark license number WM-022902.

All Billi systems are also tested to AS/NZS 4020; AS1428 Accessibility Design Requirements. Billi is also ISO 9001 Certified Certificate Number QEC11627.

Billi **Quadra** and **Quadra Plus** products are certified Gold Level under Global GreenTag LCARate standard 4.0.

Billi's range of Filter, Mixer and Sensor taps are Watermarked and licensed under WELS T14803, T40034, T40038, T40039, T40040, T40041, T40042, T26149, T30968, T36026.

Billi systems are certified under HACCP PE-972-WAT-1-02.

Billi has been a Cornerstone Member of the International WELL Building Institute (IWBI) since 2019 and certified under IWBI's 'Works With WELL' program since 2024.

*Every effort is made to ensure all certifications listed are up to date, however this list may not be extensive or in full.

Matte Black XL Dispenser with matching 120mm riser and font



**Regina, Vic**

"The Billi hot & filtered cold tap is by far the more superior product in my experience. There are 4 reasons for this. Firstly, we love the ease with which the Filter Cartridges - just slot in and click into place for replacement, couldn't be simpler. The second major advantage is the reduced and more efficient unit size that sits underneath in the cabinet below - it takes up far less room than the competitor offering. Importantly, the price point is by far lower, a real no brainer! And lastly, the unit is reliable and looks fabulous. I could not recommend the Billi tap enough. It isn't my first Billi tap, and it won't be my last"

**Marteli, NZ**

"I would like to add a thank you to your technician; he was very clear in his explanation and made it easy for me to understand. He carried out many tests that no one had done before, and it's refreshing to get to the bottom of my issue. While I understand it is an ongoing problem due to the plumbing works, the technician provided me with quick fixes in the meantime. Enjoy your afternoon!"

**Sugi Tjiu, Melbourne**

"Extremely happy with the purchase and service by Billi team. I have installed the unit for more than a year without hiccup. The convenience of using the product makes me smile every time I use it. Glad to be able to support our local Australian manufacturing that is now a rare sight. Keep up the good work!"

**Fotis, Melbourne**

"Such a convenient and good looking appliance. There isn't a day that goes by where we don't use our Billi. Easily pour boiling, chilled or sparkling filtered water at the touch of a button. This is our 2nd one, we moved into a house that didn't have a Billi and had to put one in!"

**@scotbuildshamptonhome**

Best investment ever... I love how quick I can make my coffee/tea in the morning with this instantaneous hot water Billi tap #billitap #instantaneous #instanthatdrinks #tea #coffeelover #coffee @billiwater



Billi®

Billi Australia Pty Ltd

42 Lucknow Crescent,
Thomastown, Victoria
3074 Australia

P 1800 812 321
F +61 3 9469 0499
W www.billi.com.au

Billi New Zealand Ltd

58 Walls Road,
Penrose, Auckland
1061 New Zealand

P 0800 636 0 636
F +64 9 636 8636
W www.billi.co.nz

visit us at



Billi® is a registered trademark of Billi Australia Pty Ltd. All rights reserved. © Copyright protected. As Billi Australia Pty Ltd has a policy of continual improvement, all details are subject to change without notice. All goods are sold subject to our published terms and conditions.