

COMMERCIAL DATA SHEET

Alpine 120 Square Slimline

Billi®

Billi Alpine 120 with Square Slimline Dispenser

Enjoy refreshing chilled and a continuous supply of filtered water. Billi's Alpine 120 offers a premium filtered drinking water experience.

Even after the chilled tank reserve has been depleted, the Alpine 120 is capable of dispensing a continuous stream of cool filtered water, supplied from the square slimline dispenser with single paddle lever operation.



CHILLED



Up to 25

Square Slimline Dispenser

Alpine Under-Bench Unit



Features



SPACE SAVING DESIGN



ENERGY EFFICIENT



NO CUPBOARD VENTILATION REQUIRED



UNLIMITED FILTERED WATER



ADJUSTABLE CHILLED TEMPERATURE



WATER COOLED TECHNOLOGY



RANGE OF FINISHES



EASY INSTALLATION



AUSTRALIAN DESIGNED & MADE



HACCP CERTIFIED

PRODUCT SPECIFICATIONS

Water type	Product code	Model name	Dispenser	Suggested no. of people	Chilled water delivery (cups per hour)	Power supply (amps)
 CHILLED	932120S	Alpine 120	Square Slimline	Up to 25	120	10

Accessories

992810 - Slimline Font

990724 - Tubing Extension Kit for Slimline 2mtrs



Finishes

Standard Finishes

CH - Chrome

BR - Brushed

MB - Matte Black

MW - Matte White

Special Order Finishes

RG - Rose Gold

BRG - Brushed Rose Gold

PL - Platinum

UB - Urban Brass

GM - Gun Metal Grey

Add the Finish code to the Product Code to finalise your specification, eg. 932120SMB

TECHNICAL DRAWING & INSTALLATION REQUIREMENTS

PRODUCT DIMENSIONS

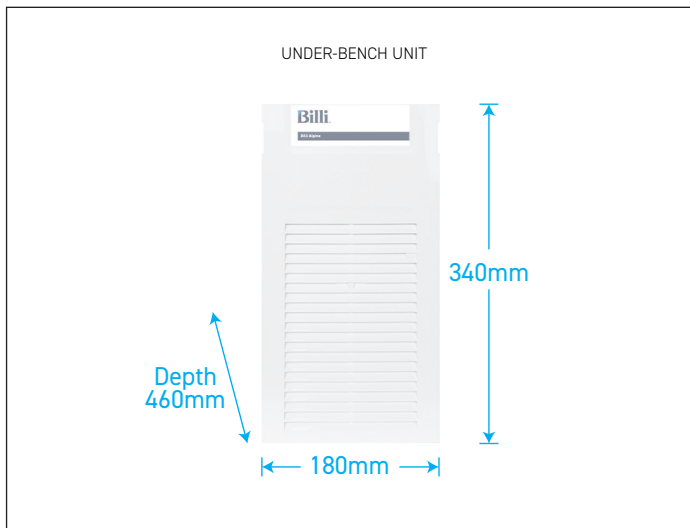
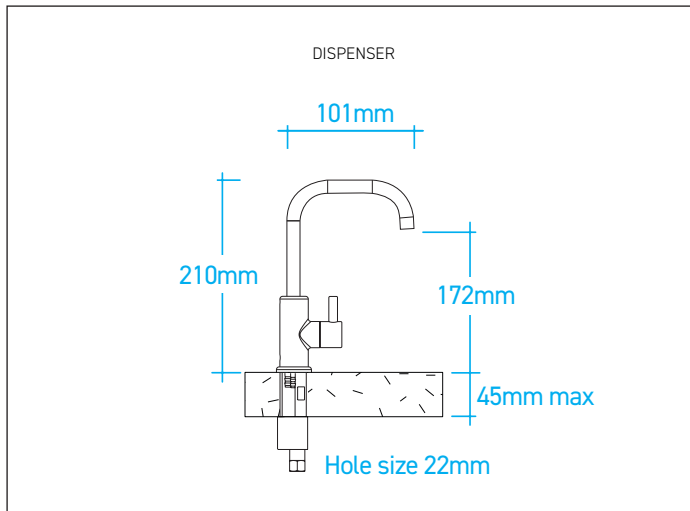

PREFERRED INSTALLATION LAYOUT

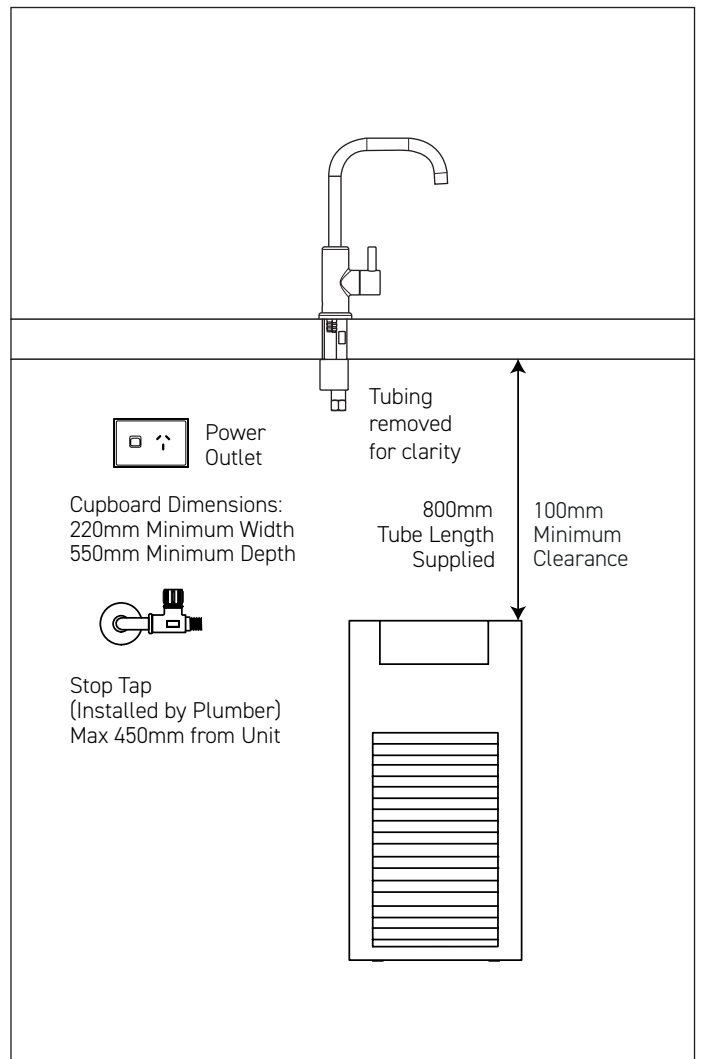

WATER SUPPLY

A single 1/2" BSP (15mm) stop-tap with a male thread should be installed in an easily accessible position. Water supply must be microbiologically safe to drink, with a minimum dynamic water pressure of 250kPa and a maximum of 1000kPa.

POWER SUPPLY

A standard 10 amp power outlet is required, no further than 1000mm from the underbench unit. The system is supplied with a 1 metre flex cord and plug.

FILTRATION

Billi's range of premium filters utilise BWT's unique Fibron X technology. Billi's filter range provides superior taste, water quality, consistent filter life and peace of mind when it comes to hygiene.

Filter supplied: 994051 (5 micron). Replacement filters available: 994052 (0.2 micron), 994054 (HSD), 994055 (XPHSD), 994056 (Sediment only) and 994060 (0.2 micron sediment only).

CERTIFICATIONS

Every Billi drinking water appliance is manufactured under a certified quality control system. All Billi commercial range models have been tested and comply with all required standards including: Watermark: WM-021882; HACCP: PE-872-WAT-1-02; ISO 9001:2015, QEC 11627; Tested to ATS5200.105 and AS/NZ 4020; Section J6.6 of the BCA; WELL Cornerstone Member; WELS 6 star rating registration T26065.

WARRANTY

The Billi Alpine Range is covered by a comprehensive 2 year warranty on all parts and labour.

Billi®



Billi Australia Pty Ltd

P 1800 812 321
W www.billi.com.au

Billi New Zealand Ltd T/As Merquip

P 0800 636 0 636
W www.merquip.co.nz

visit us at

