

# COMMERCIAL DATA SHEET

## Quadra Sparkling 460 XL

# Billi®

### Billi Quadra Sparkling 460 with XL Levered Dispenser

The Quadra Sparkling is the ultimate in modern design and filtered drinking water appliances delivering instant boiling and chilled filtered water, with the added luxury of sparkling water.

Utilising underbench ice bank technology to enhance capacity and recovery, all three output options are conveniently delivered by operating the DDA compliant position sensitive levers on the single above bench XL levered dispenser.

The Quadra Sparkling has a commercial capacity and is suitable for any environment.



BOILING



CHILLED



SPARKLING



Up to 60

XL Levered Dispenser

Quadra Sparkling Under-Bench Unit



### Features



SAFE TO OPERATE



ECO-INTELLIGENCE TECHNOLOGY



ADJUSTABLE CHILLED TEMPERATURE



ADJUSTABLE SPARKLING LEVEL



ICE BANK TECHNOLOGY



PLUS MODEL AVAILABLE



RANGE OF FINISHES



HACCP CERTIFIED



ITALO-AUSTRALIAN PARTNERSHIP

# Australian Made Boiling Unit \* Italian Design & Made Sparkling Unit

## PRODUCT SPECIFICATIONS

Water type	Product code	Model name	Dispenser	Suggested no. of people	Boiling water delivery (cups per hour)*	Chilled & Sparkling water delivery (cups per hour)	Power supply (amps)
BOILING CHILLED SPARKLING	906060L	Quadra Sparkling 460	XL Levered	Up to 60	Up to 165	200	2 x10

\* Based on a set volume of water being drawn every 30 seconds at an inlet temperature of average temperature 21°C. Each cup is equivalent to 170ml. Usage patterns and draw-off methods can impact recovery.

### Accessories

992800 - 70mm Riser & Font



992820 - 70mm Riser



992803 - 120mm Riser & Font



992830 - 120mm Riser



990726 - Tubing Extension Kit for Sparkling unit - 2mtrs

### Finishes

#### Standard Finishes

CH - Chrome	BR - Brushed
MB - Matte Black	MW - Matte White

#### Special Order Finishes

RG - Rose Gold	BRG - Brushed Rose Gold	GM - Gun Metal Grey
PL - Platinum	UB - Urban Brass	

Add the Finish code to the Product Code to finalise your specification, eg. 906060LMB

# TECHNICAL DRAWING & INSTALLATION REQUIREMENTS

## PRODUCT DIMENSIONS

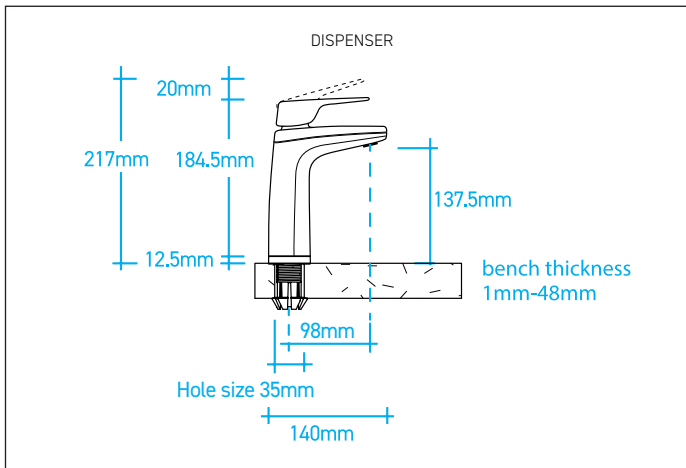

## PREFERRED INSTALLATION LAYOUT

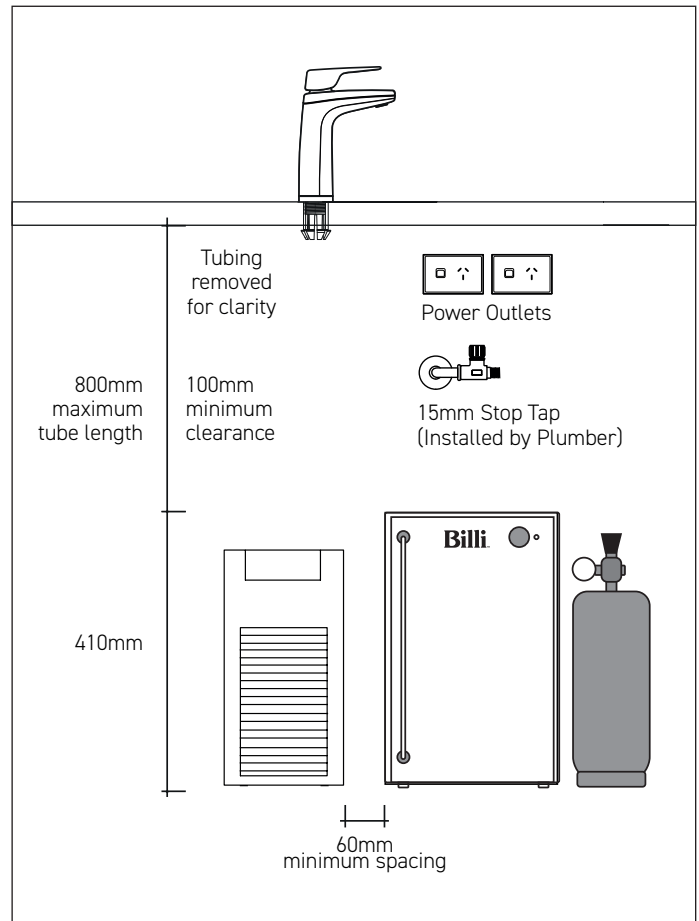

### WATER SUPPLY

A single 1/2" BSP (15mm) stop-tap with a male thread should be installed in an easily accessible position. Water supply must be microbiologically safe to drink, with a minimum dynamic water pressure of 250kPa and a maximum of 1000kPa.

### POWER SUPPLY

Two (2 of) standard 10 amp power outlets are required, no further than 1000mm from the underbench unit. The system is supplied with a 1 metre flex cord and plug.

### FILTRATION

Billi's range of premium filters utilise BWT's unique Fibron X technology. Billi's filter range provides superior taste, water quality, consistent filter life and peace of mind when it comes to hygiene.

Filter supplied: 994051 (5 micron). Replacement filters available: 994052 (0.2 micron), 994054 (HSD), 994055 (XPHSD), 994056 (Sediment only) and 994060 (0.2 micron sediment only).

### CERTIFICATIONS

Every Billi drinking water appliance is manufactured under a certified quality control system. All Billi commercial range models have been tested and comply with all required standards including: Watermark: WM-022690; Tested to ATS5200.105 and AS/NZ 4020; ISO 9001:2015, QEC 11627; AS1428; HACCP: PE-872-WAT-1-02; WELL Cornerstone Member.

### CO2 Cylinder

The CO2 gas cylinder supplied must be secured in a suitable location. Each cylinder contains 1100g of CO2 and should be installed in a well ventilated area. Each cylinder will provide between 200-350L of sparkling water depending on the unit settings. The MSDS is available on [www.billi.com.au](http://www.billi.com.au) for a complete list of specifications and warnings. Replacement gas cylinders are available from Billi. CO2 Cylinder - single 996911 or double 996912.

### WARRANTY

The Billi Quadra Sparkling Range is covered by a comprehensive 2 year warranty on all parts and labour.

# Billi



Billi Australia Pty Ltd

P 1800 812 321

W [www.billi.com.au](http://www.billi.com.au)

Billi New Zealand Ltd T/As Merquip

P 0800 636 0 636

W [www.merquip.co.nz](http://www.merquip.co.nz)

visit us at



Share your content



Product reviews

Customer support

Warranty registration