

COMMERCIAL DATA SHEET

Sahara 3120 XR

Billi®

Billi Sahara 3120 with XR Remote Dispenser

The Sahara 3120 Boiling and Still drinking water system is a large commercial capacity system, but still maintains Billi's core design principles of space saving while requiring no joinery ventilation.

Offering both boiling water and a bottomless supply of filtered ambient temperature water, the Sahara range is convenient and functional.

The XR remote dispenser is an innovative and thoughtful design, with the potential for ambulant or wheelchair inclusive access via the remote control panel.



BOILING

STILL



Up to 120

XR Remote Dispenser



Sahara Under-Bench Unit



Features



PRODUCT SPECIFICATIONS

Water type	Product code	Model name	Dispenser	Suggested no. of people	Boiling water delivery (cups per hour)*	Still water delivery (cups per hour)	Power supply (amps)
  BOILING STILL	943120R	Sahara 3120	XR Remote	Up to 120	Up to 220	Unlimited	15

* Based on a set volume of water being drawn every 30 seconds at an inlet temperature of average temperature 21°C. Each cup is equivalent to 170ml. Usage patterns and draw-off methods can impact recovery.

Accessories

992800 - 70mm Riser & Font

992820 - 70mm Riser

992803 - 120mm Riser & Font

992830 - 120mm Riser



990720 - Tubing Extension Kit for X series dual temp dispensers 2mtrs

Finishes

Standard Finish

CH - Chrome

Add the Finish code to the Product Code to finalise your specification, eg. 943120RCH

TECHNICAL DRAWING & INSTALLATION REQUIREMENTS

PRODUCT DIMENSIONS

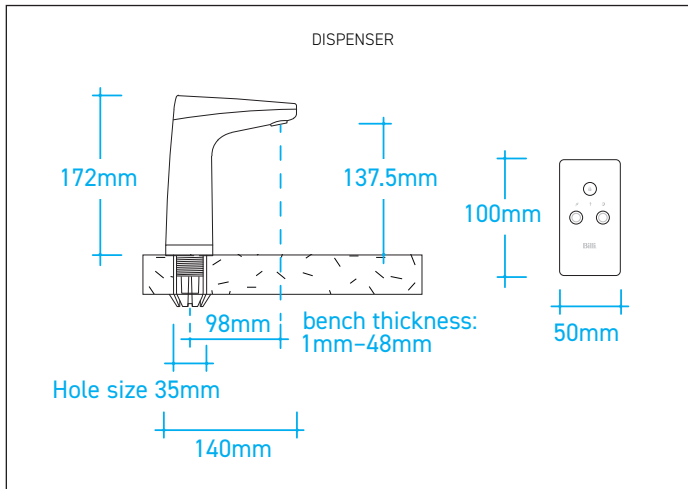

PREFERRED INSTALLATION LAYOUT

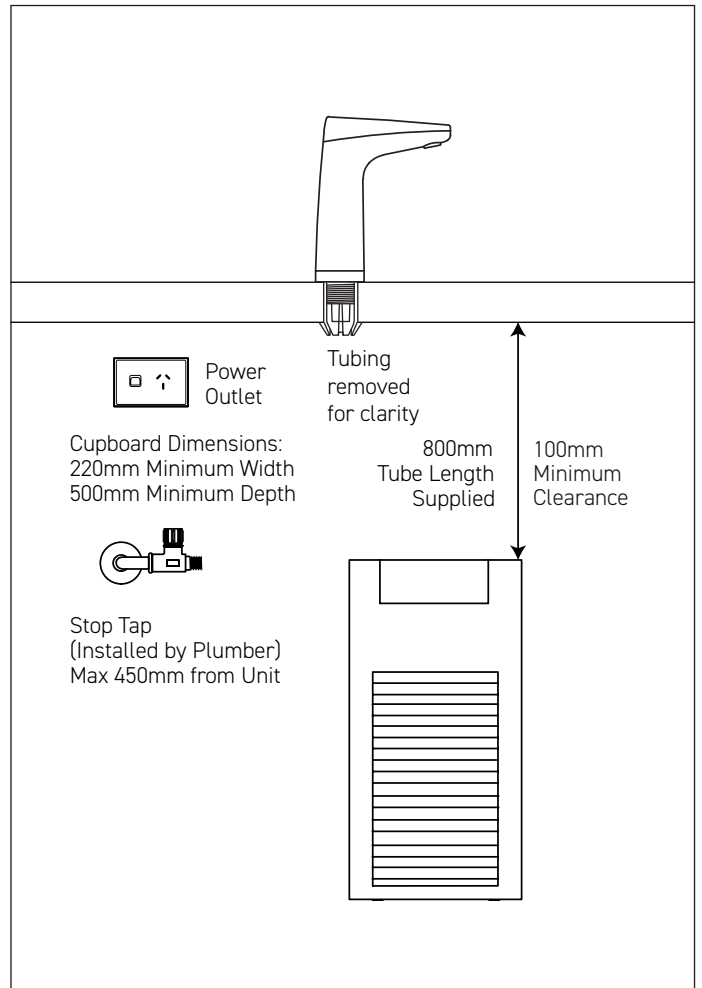

WATER SUPPLY

A single 1/2" BSP (15mm) stop-tap with a male thread should be installed in an easily accessible position. Water supply must be microbiologically safe to drink, with a minimum dynamic water pressure of 250kPa and a maximum of 1000kPa.

POWER SUPPLY

A standard 15 amp power outlet is required, no further than 1000mm from the underbench unit. The system is supplied with a 1 metre flex cord and plug.

FILTRATION

Billi's range of premium filters utilise BWT's unique Fibron X technology. Billi's filter range provides superior taste, water quality, consistent filter life and peace of mind when it comes to hygiene.

Filter supplied: 994051 (5 micron). Replacement filters available: 994052 (0.2 micron), 994054 (HSD), 994055 (XPHSD), 994056 (Sediment only) and 994060 (0.2 micron sediment only).

CERTIFICATIONS

Every Billi drinking water appliance is manufactured under a certified quality control system. All Billi commercial range models have been tested and comply with all required standards including: WaterMark: WM-021525; Certified to AS/NZ3498 and AS/NZ 4020; ISO9001:2015, QEC 11627; Section J6.6 of the BCA; HACCP: PE-872-WAT-1-02; WELL Cornerstone Member.

WARRANTY

The Billi Sahara Range is covered by a comprehensive 2 year warranty on all parts and labour.

Billi®



Billi Australia Pty Ltd

P 1800 812 321

W www.billi.com.au

Billi New Zealand Ltd T/As Merquip

P 0800 636 0 636

W www.merquip.co.nz

visit us at

