

Installation / Use Manual

Original Instructions

**Models: LZSTL8WSL2K, LZSTL8WSS2K, LZSTL8WSVRL2K,
LZSTL8WSVRS2K**



Description

Combination Refrigerated Drinking Fountain (Cooler) with bottle filling station delivers chilled, clean potable drinking water. Two-level water cooler houses the refrigeration and delivers a steady stream of water for direct drinking at the press of the front and sidebars.

Ratings

- Electrical: 230Vac, 50Hz, (See Nameplate for Amperage), 1 phase.
- Ambient Air Temperature: 50-100.4 °F (10-38 °C).
- Water Pressure: 20-100 psig (0.14-0.69 MPa).
- Maximum Water Temperature: 90 °F (32 °C).
- Refrigerant: HFC-R134a
- Ingress Protection: IP2x
- For Indoor Commercial Use only.
- Water Inlet: 3/8" (9.5mm) O.D. unplated copper tube.
- Waste Water Outlet: 1-1/2" (38.1mm) O.D. tube

Definitions

DANGER – Indicates death or serious injury will result if proper precautions are not taken.

WARNING – Indicates death, serious injury or property damage can result if proper precautions are not taken.

CAUTION – Indicates some injury or property damage may result if proper precautions are not taken.

Authorized Service Personnel – Factory trained personnel or personnel having working knowledge of electrical, plumbing and machine (appliance) maintenance procedures.

Safety

DANGER

- Please read these instructions completely before starting the installation or performing any service. Failure to follow the instructions and safety precautions in this manual can result in serious injury or death.
- After installation, keep these instructions in a safe location for future reference.

- Electric supply must be identical in voltage, cycle, and phase to that specified on nameplate.
- Electrical supply must have Ground Fault Circuit Interrupter (GFCI) protection.
- A means for disconnecting electrical supply to the unit must be incorporated in the fixed wiring in accordance with wiring rules. This is to allow electrical disconnection of the unit from electrical supply after installation.

WARNING

- For use with clean, clear potable drinking water only. Do not use with water that is microbiologically unsafe or of unknown quality without adequate disinfection before the system.
- Installation and connection to water and electrical mains must be in compliance with local and national laws.
- All Installation and Service work must be performed by an authorized service personnel.

CAUTION

- This appliance can be used by children aged from 8 years and above and persons with reduced physical, sensory, or mental capabilities or lack of experience and knowledge if they have been given supervision or instructions concerning use of the appliance in a safe way and understand the hazards involved. Children shall not play with the appliance. Cleaning and user maintenance shall not be made by children without supervision.
- To prevent a metallic taste or increased metal content in the water due to an electrolysis process caused by electrical feedback from the grounding of electrical equipment to water supply and water waste mains, connect to these mains using non-conductive materials. The provided solenoid valve regulator assembly meets this requirement.

Installation

For correct and safe installation, please read these instructions completely.

DANGER

- All Installation work must be performed by an authorized service personnel.
- Disconnect electrical supply serving the Installation area to reduce risk of electrocution.
- Unit not suitable for installations where water jets could be used.

WARNING

- Shut off water supply serving the Installation area to reduce risk of water damage.
- Ensure proper ventilation by maintaining clearance from cabinet louvers to wall on each side of Cooler as specified in Rough-In.
- Never wire compressor directly to electrical supply.
- Thoroughly flush all water lines and fittings of all foreign matter before connecting to Cooler.
- Warranty is void if Installation is not made in accordance with current Manufacturing instructions.

CAUTION

- Hose-sets are not to be used for connecting to water mains.
- If inlet pressure is above 100 psig (0.69 MPa), a pressure regulator must be installed in water supply line. Any damage caused by reason of connecting this product to water supply line pressure outside it's rated pressure, is not covered by warranty.
- Tools/Items required but not provided.
 - o Water Shut-off Valve with 3/8" (9.5mm) compression outlet.
 - o Waste Trap (non-metallic)
 - o Safety Glasses
 - o Protective Gloves
 - o 5/16" (8mm) Hex Socket or Flathead Screwdriver
 - o 5/32" (4mm) Hex Key
 - o Fasteners for wall type.

Installation: Cooler Mounting

1. Remove Hanger Bracket (Item 1) fastened to back of cooler by removing one (1) screw.
2. Mount Hanger Bracket as shown in Figure 5, 6, 7, or 8.
 - NOTE: Hanger Bracket MUST be supported securely. Add fixture support carrier if wall will not provide adequate support. Anchor hanger securely to wall using all six (6) 1/4" (6.4mm) diameter mounting holes.
3. Hang Cooler on the Hanger Bracket. Be certain the Hanger Bracket is engaged properly in the slots on the cooler back as shown in Figure 5, 6, 7, or 8.
4. Remove the four (4) screws holding the lower front panel at the bottom of cooler. Remove the front panel by pulling straight down and set aside.

Installation: Water Line connection

1. Ensure Mains Water Supply has Water Shut-off Valve with 3/8" (9.5mm) compression outlet.
2. Connect loose end of supplied 3/8" (9.5mm) unplated copper tube to Water Shut-off Valve. Other end of tube should be connected to inlet of Filter head. If not connected, simply insert into inlet fitting on Filter head until positive stop – approximately 3/4" (19mm). Then tighten locknut handtight to seal.
 - NOTE: If 3/8" (9.5mm) copper tube must be cut for proper fit, remove all burrs from the outside of tube and re-flush before use.
3. Install filter cartridge. Remove filter from carton, remove protective cap, and attach filter to filter head by firmly inserting into head and rotating filter clockwise.
 - **IMPORTANT: DO NOT TURN ON WATER BEFORE INSTALLING BOTTLE FILLER**

Installation: Waste Line connection

1. Install waste trap. Remove the slip nut and gasket from the waste trap and install them on the cooler waste line making sure that the end of the waste line fits into the waste trap. Assemble the slip nut and gasket to the waste trap and tighten securely.
 - **IMPORTANT: If it is necessary to cut the drain, loosen the screw at the black rubber boot and remove tube, check for leaks after reassembly**
2. It is recommended that the waste trap be insulated to avoid excessive condensation due to chilled water running through the waste trap.
3. Turn on building water supply and open Water Shut-off Valve. Check all connections for leaks and correct any found.

Installation: Bottle Filler

1. Remove two (2) mounting screws holding top cover to bottle filler with a 5/32" (4mm) Hex Key (See Figure 2). Remove top cover. Note: Do not discard mounting screws; they will be needed to re-install top cover.
2. Remove wall mounting plate from bottle filler. Place wall plate against wall on top of basin. Center the wall plate side to side with the basin. Mark the six (6) mounting holes with a pencil. See Figure 5, 6, 7, or 8.
3. Remove the wall mounting plate from wall. **Note:** Mounting plate **MUST** be supported securely. Add fixture support carrier if wall will not provide adequate support.
4. Install wall mounting plate to wall using six (6) 7/16" (11.1mm) obround mounting holes (mounting bolts not provided). See Figure 1. Use appropriate fasteners for your wall type.
5. Feed 3/8" (9.5mm) water line through hole in tower/basin gasket. See Figure 3.
6. Install gasket on bottom of bottle filler tower with gasket support bracket and (2) screws. See Figure 4.
7. Feed modular (C-13) end of International Power Cord Set up through basin hole and hole in gasket. Connect to Power Inlet on Bottle Filler. Do not plug into electrical outlet.
8. With the power cord and waterline through the hole on top of water cooler place bottle filler on three (3) angled tabs protruding from the wall mounting plate installed on wall. Make sure round boss in gasket fits in hole of basin. See Figure 11.
9. Once bottle filler is installed on wall plate tabs, waterline, wires, and power cord are installed properly, push top of bottle filler toward wall and line up two (2) holes on top cover.
10. Re-install top cover on bottle filler (See Figure 2) with two (2) mounting screws from step 1 above. **Caution:** Do not over tighten screws.
11. Install remaining tube insulation to the water line from bottle filler, connect bottle filler waterline inside of the water cooler by connecting the 3/8" (9.5mm) waterline to the tee.

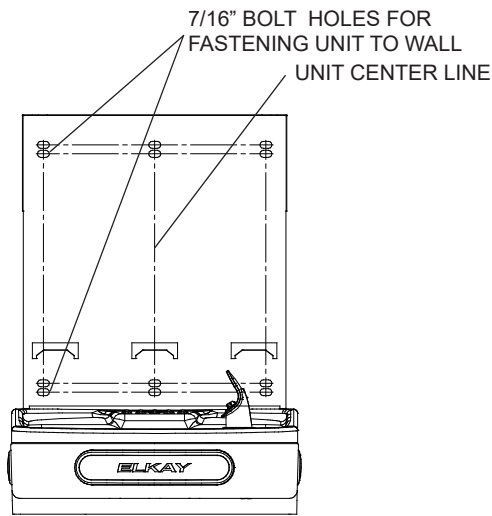

Figure 1

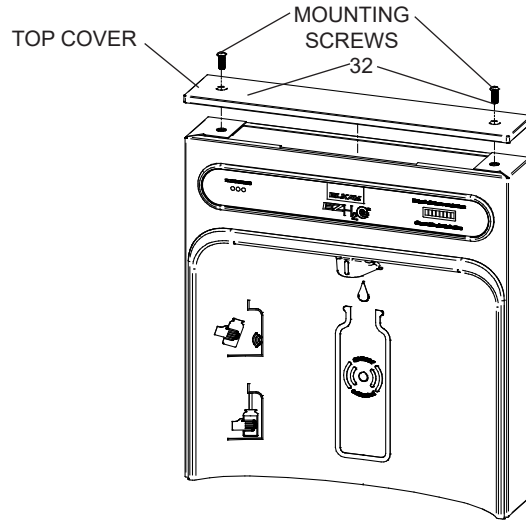

Figure 2

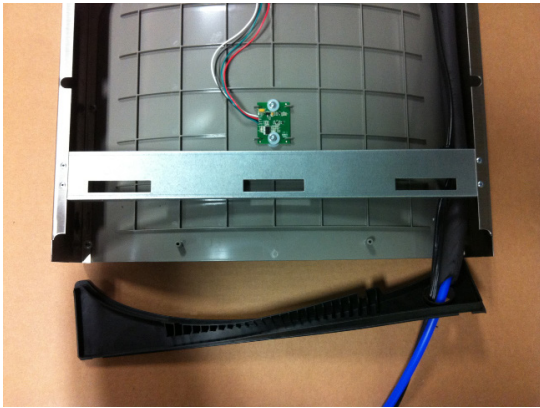
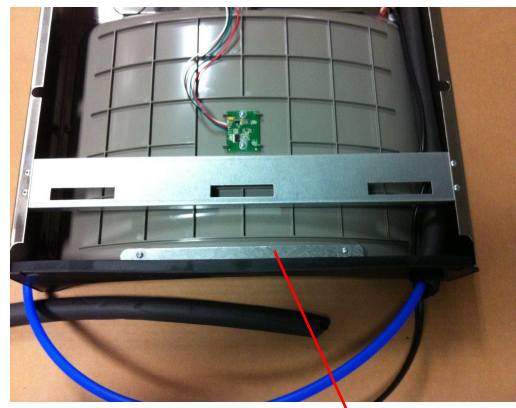

Figure 3



BRACKET & SCREWS

Figure 4

Installation: Electrical connection

1. Rotate fan to ensure proper clearance and free fan action.
2. Connect modular (C-13) end of International Power Cord Set (sold separately) into power inlet on both fountains and bottler filler. Ensure plug-end reaches electrical outlet. Do not plug into electrical outlet!

Operation: Start-Up

1. Turn on the building water supply and check all connections for leaks. Fix any leaks before proceeding.
2. Rotate fan to ensure proper clearance and free fan action.
3. Connect plug-end of International Power Cord Set (sold separately) into electrical outlet.

WARNING: Exposed electrically energized components. Use extreme caution.

4. After power has been applied, wait for the Green LED to illuminate, showing good filter status. Wait for LCD screen to display bottle count.
5. Purge air from all water lines by depressing push bars on each fountain one at a time. Place a cup, hand, or other opaque object in front of sensor area on bottle filler and purge air from waterline. **Note:** Initial activation may sputter due to air in water lines.
6. Re-check all water and drain connections with water flowing through system.
7. After verifying that the water cooler is properly connected and operational, replace and reattach the cooler lower front panels by retightening screws.

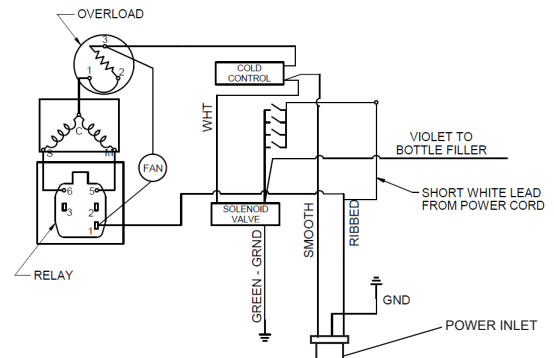

230V Wiring Diagram

Standard Rough-In: LZSTL8WSL2K - Left hand high, bottle filler low

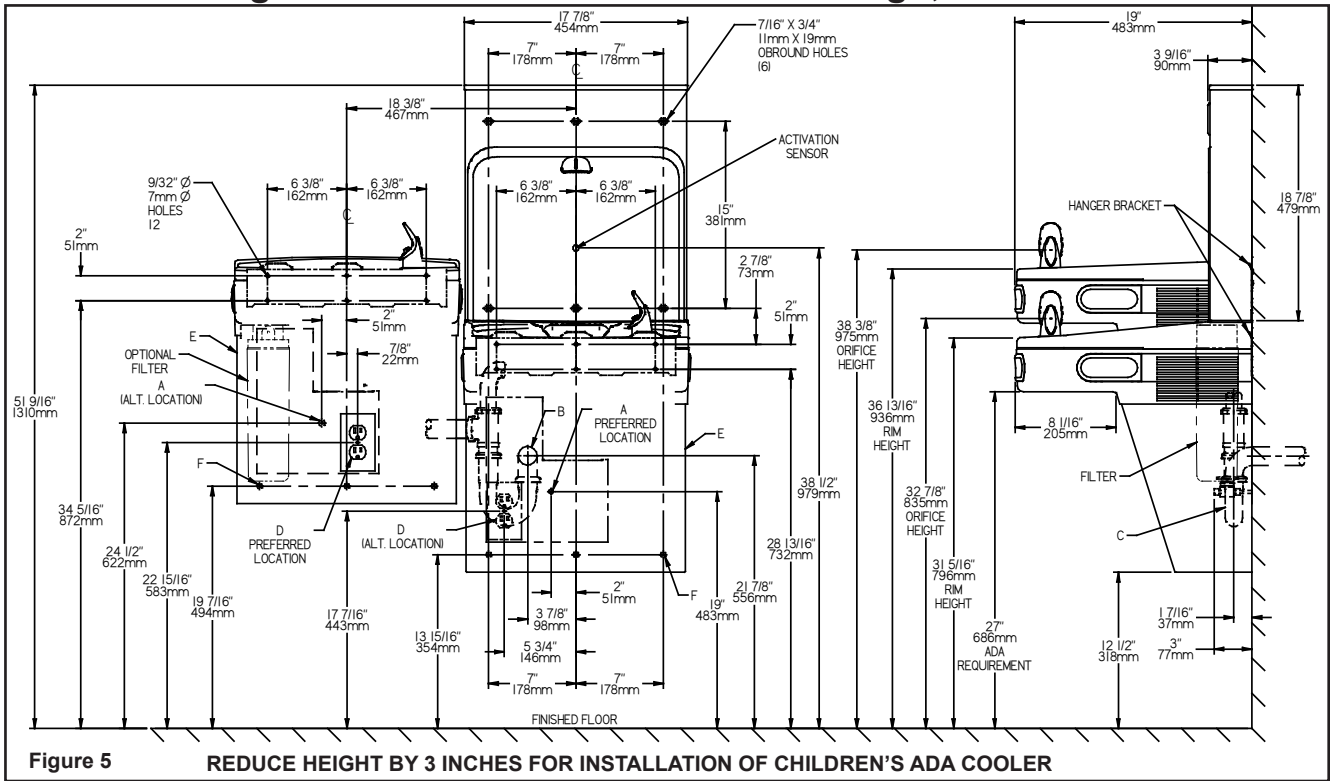

Figure 5 REDUCE HEIGHT BY 3 INCHES FOR INSTALLATION OF CHILDREN'S ADA COOLER

Alternate Rough-In: LZSTL8WSL2K - Right hand high, bottle filler low Requires Basin Assembly Change: See Pages 11-15 for instructions.

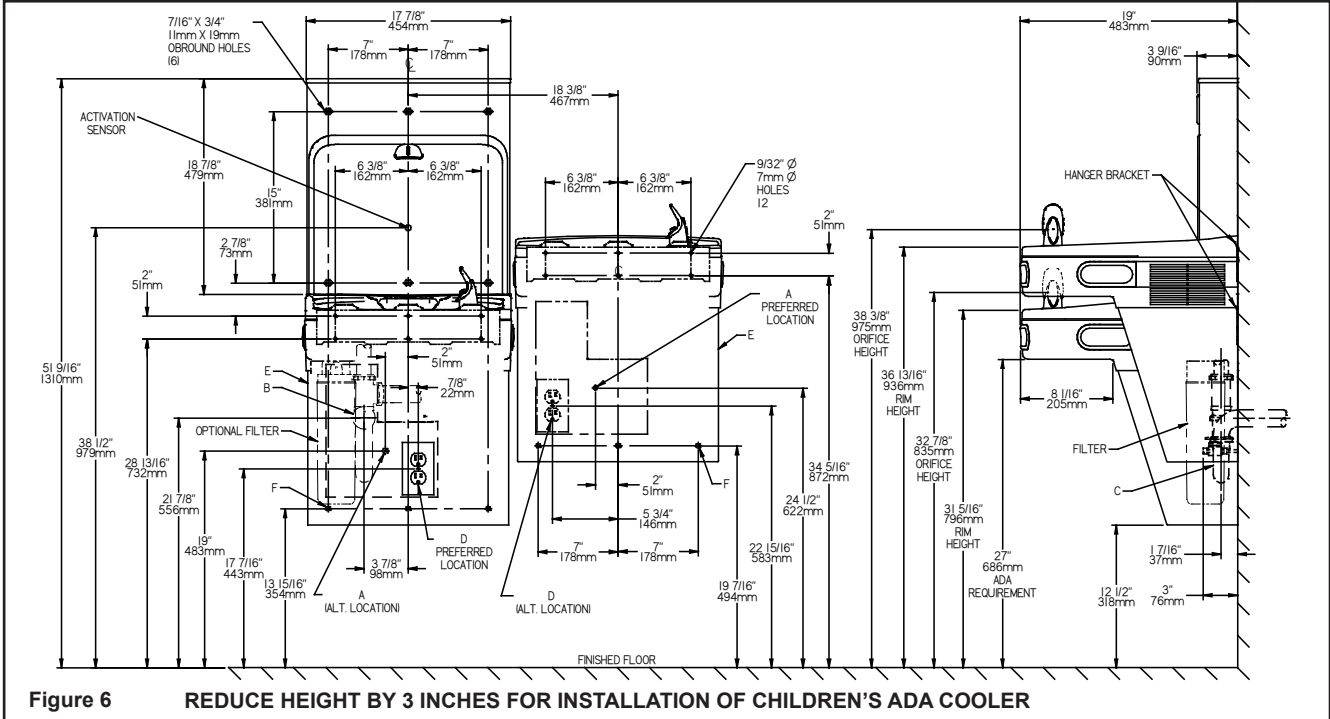
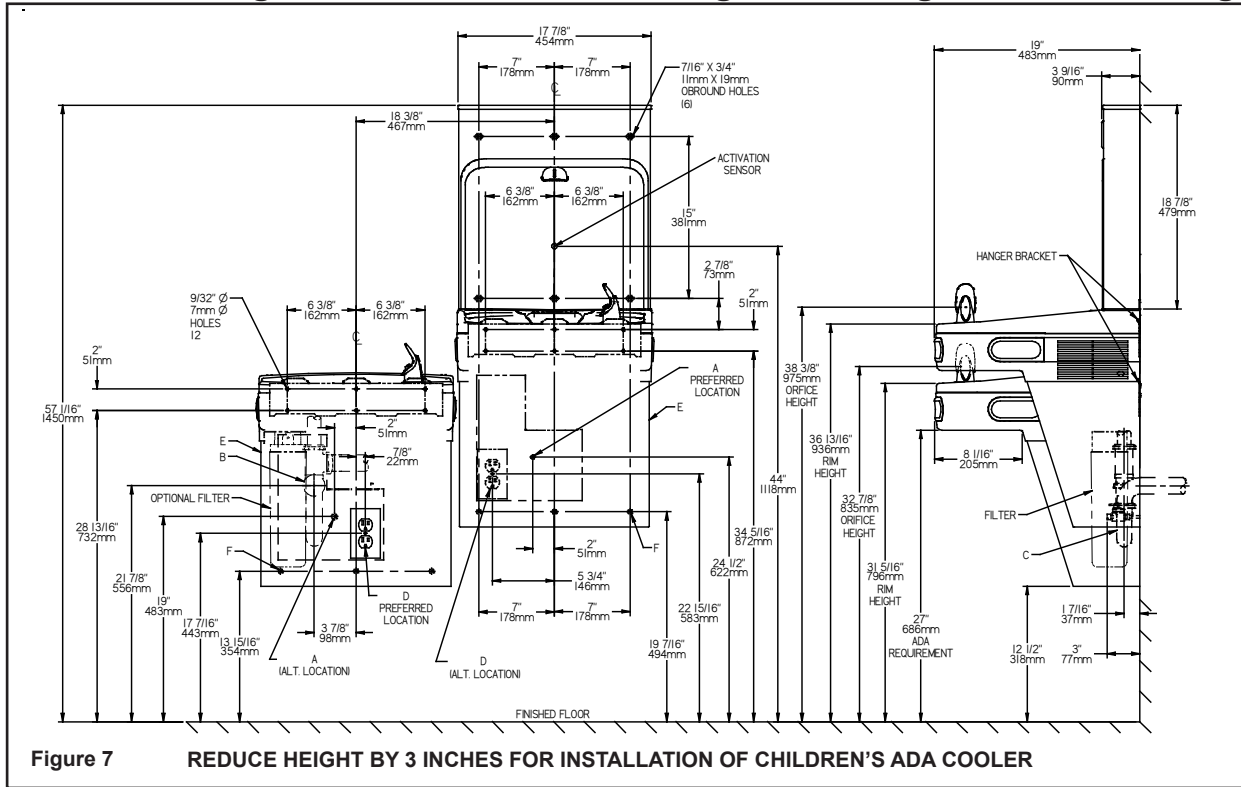

Figure 6 REDUCE HEIGHT BY 3 INCHES FOR INSTALLATION OF CHILDREN'S ADA COOLER

LEGEND

- A = Water Mains Supply, 3/8" (9.5mm) O.D. compression outlet of Shut-off Valve (not provided) to be 3" (76mm) from Wall.
- B = Waste Outlet, 1-1/2" (38.1mm) O.D. Drain Tube terminating 2" (51mm) maximum from Wall.
- C = 1-1/2" (38.1mm) trap (not provided).
- D = Electrical Mains Supply Outlet, 3-wire in Recessed Box. Must have Ground Fault Circuit Interrupter (GFCI) protection.
- E = Ensure proper ventilation by maintaining 6" (152mm) minimum clearance from cabinet louvers to wall.
- F = 7/16" (11mm) Bolt holes for fastening unit to wall.

Alternate Rough-In: LZSTL8WSL2K - Right hand high, bottle filler high



**Alternate Rough-In: LZSTL8WSL2K - Right hand high, bottle filler low
Requires Basin Assembly Change: See Pages 11-15 for instructions.**

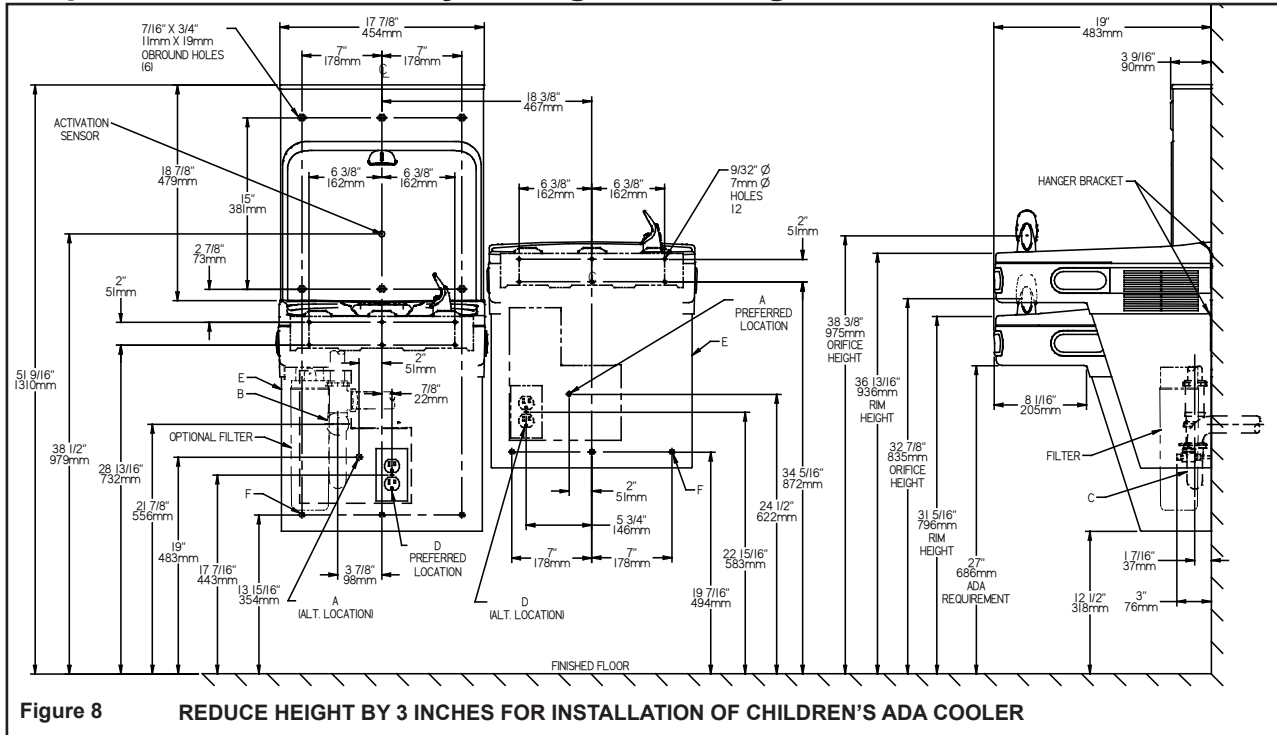

LEGEND

- A = Water Mains Supply, 3/8" (9.5mm) O.D. compression outlet of Shut-off Valve (not provided) to be 3" (76mm) from Wall.
- B = Waste Outlet, 1-1/2" (38.1mm) O.D. Drain Tube terminating 2' (51mm) maximum from Wall.
- C = 1-1/2" (38.1mm) trap (not provided).
- D = Electrical Mains Supply Outlet, 3-wire in Recessed Box. Must have Ground Fault Circuit Interrupter (GFCI) protection.
- E = Ensure proper ventilation by maintaining 6" (152mm) minimum clearance from cabinet louvers to wall.
- F = 7/16" (11mm) Bolt holes for fastening unit to wall.

Service

For proper and safe servicing, please read these instructions completely.

DANGER

- All Service and Maintenance must be performed by an authorized service personnel.
- Disconnect electrical supply to the unit before any service work to reduce risk of electrocution.
- Shut off water supply serving the unit before any service work to reduce risk of water damage.

CAUTION

- Tools/Items required but not provided, for Servicing:
 - o Safety Glasses
 - o Protective gloves
 - o 5/16" (8mm) Hex Socket or Flathead Screwdriver
 - o 5/32" (4mm) Hex Key

Service: Adjustments

1. Temperature Control: Factory set for 50°F ± 5° (10°C ± 2.8°) water under normal conditions. To adjust water temperature, turn screw on Item No. 13 clockwise for colder, counter clockwise for warmer.
2. Water Stream Height: Stream height is factory set at 35 psig (0.24 MPa). If supply pressure varies greatly from this, adjust screw located on the right knee clearance area side at bottom of the switch shroud. Clockwise adjustment will raise stream and Counterclockwise adjustment will lower stream. For best adjustment, stream should hit basin approximately 6-1/2" (165mm) from bubbler on the downward slope of the basin.
3. Water coming out of Bubbler continuously: When this occurs at the end of the compressor cycle, turn the cold control warmer (counterclockwise) ¼ turn.

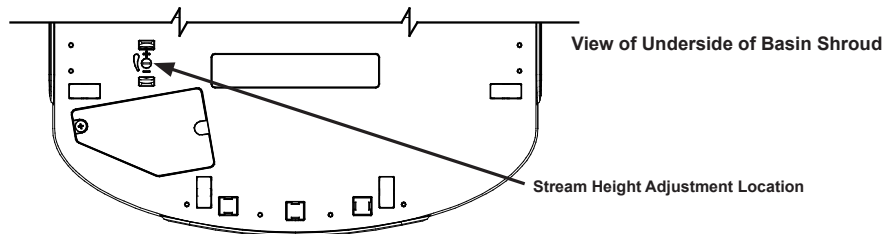

Service: Inspection/Cleaning

- Inspect Cooler twice each year for proper operation and performance.
 - Inspection of the unit will require disconnecting electrical supply, removal of panels, etc. and reassembly and return to service practices.
1. Cleaning: Warm, soapy water or mild household cleaning products can be used to clean the exterior panels. Extra caution should be used to clean the mirror finished stainless steel panels. They can be easily scratched and should only be cleaned with mild soap and water or Windex glass cleaner and a clean, soft cloth. Use of harsh chemicals or petroleum based or abrasive cleaners will void the warranty.
 2. Bubbler: Mineral deposits on the orifice can cause water flow to spurt or not regulate. Mineral deposits may be removed from the orifice with a small round file not over 1/8" (3 mm) diameter or small diameter wire.
 - CAUTION : DO NOT file or cut orifice material. Care must be taken not to damage the orifice(s)
 3. Condenser Fan Motor: Confirm condenser fan turns freely. If the condenser fan does not spin freely, have an authorized service personnel replace.
 4. Ventilation: Cabinet louvers and condenser fins should be periodically cleaned with a brush, air hose or vacuum cleaner. Cleaning should be done twice each year or more frequently if needed due to environment. Excess dirt or poor ventilation can cause no cold water and compressor cycling on the compressor overload protector.
 5. Water Flow: Confirm proper water flow. If water flow is slow, inspect filter or inline strainer for restriction. Replace filter cartridge if required. Disassemble inline strainer and clean if required.
 6. Lubrication: Motors are lifetime lubricated.
 7. Actuation of Quick Connect Water Fittings: Cooler is provided with lead-free connectors which utilize o-ring water seal. To remove tubing from the fitting, relieve water pressure, push in on the gray collar before pulling on the tubing. To insert tubing, push tube straight into fitting until it reaches a positive stop, approximately 3/4" (19mm). See Figure 10.

Service: Inspection/Replacement

- Inspect Cooler twice each year for proper operation and performance.
 - Inspection of the unit will require disconnecting electrical supply, removal of panels, etc. and reassembly and return to service practices.
1. Lower Front Panel and Upper Shroud: To access the refrigeration system and plumbing connections, remove four (4) screws from bottom of cooler to remove the lower front panel. To remove the upper shroud (Item 6) for access to the pushbars, regulator, solenoid valve or other components located in the top of the unit, remove lower panel, disconnect drain, remove four screws from tabs along lower edge of upper shroud, unplug two wires and water tube.
 2. Bubbler: To remove the bubbler, first disconnect the electrical supply. The underside of the bubbler can be reached through the access panel on the underside of the upper shroud. Remove the access panel by removing the retaining screw. To remove the bubbler, loosen locknut from the underside of the bubbler and remove the tubing from the quick connect fitting (see Figure 10). When installing replacement bubbler and pedestal, tighten nut only to hold parts snug in position. Do Not Overtighten. After servicing, replace the lower front panel and four (4) screws.
 3. Switches Behind the Push Bar: The regulator in an EZ cooler is always held fully open by the use of a single regulator nut. Water is not dispensed until the pushbar is depressed to activate a switch which then opens a solenoid valve. When installing the regulator nut, the regulator spring must be depressed while turning the nut. To remove sidebars, from the inside compress the flared tabs and pull out carefully. To reinstall side pushbars, the front of the pushbar is inserted first. While keeping the switch depressed, snap the rear of the pushbar into position.
 4. Cleaning In-Line Strainer: Unscrew the cap of the In-Line Strainer. Remove screen and rinse thoroughly with water. Insert screen back into In-Line Strainer and screw cap on. Make sure the o-ring is placed properly.

BF11 - BF12 PROGRAM

SETTING THE CONTROL BOARD

VERIFY CONTROL BOARD SOFTWARE

- 1) To verify the software program of the control board the unit will need to be shut down and restarted. The chiller (if present) does not need to be shut down and restarted.
- 2) The units lower panel must be open to access the power cord and wall outlet.
- 3) Shut down the unit by unplugging the power cord from the wall outlet.
- 4) Restart the unit by plugging the power cord back into the wall outlet.
- 5) Upon start up, the bottle count display will show the software designation of BF11 or BF12.

ACCESSING THE PROGRAMMING BUTTON

- 1) To access the program button, remove the top cover of the bottle-filler. Remove the two (2) screws holding top cover to bottle-filler with a 5/32" allen wrench. Remove top cover. Do not discard mounting screws, they will be needed to reinstall the top cover after programming operations are completed. The programming button is located at the top right side of the unit on the control board.

NOTE: When applicable, there is also an alternate reset button located on the lower part of the water cooler. After removing the bottom cover, the reset button will be located on the left side of the cooler, mounted on the side panel support.

RESET THE FILTER MONITOR

- 1) Instructions apply to filtered units only.
- 2) Depress the program button for approximately 2 seconds until the display changes then release. The display will change and scroll through two messages:
"RST FLTR" – Reset Filter Monitor
"SETTINGS" – System Settings Sub Menu
If the program button is not pushed again the display will scroll through the two messages above for three cycles and then default back to bottle count and be back in run mode.
- 3) When the display changes to "RST FLTR", depress the button again. The display will change to show "FLTR =". Depress the button again and the display will show "FLTR =0"
- 4) The Green LED should be illuminated indicating that the visual filter monitor has been reset.

SETTING RANGE OF THE IR SENSOR WHERE APPLICABLE

- 1) Depress the program button for approximately 2 seconds until the display changes then release. The display will change and scroll through two messages:
"RST FLTR" – Reset Filter Status LED
"SETTINGS" – System Settings Sub Menu
If the program button is not pushed again the display will scroll through the two messages above for three cycles and then default back to bottle count and be back in run mode.
- 2) When the display changes to "SETTINGS", depress the button again. The display will change to show
"RNG SET" - Range set for IR sensor.
"UNIT TYP" - Type of unit (REFRIG or NON-RFRG)
"FLT SIZE" - Select filter capacity
"RST BCNT" - Reset bottle count
- 3) When display shows "RNG SET" push program button once the display will show current value (can be 1 – 10) e.g. "RNG = 3".
- 4) Once display shows current value push the program button to scroll through value of 1 – 10. Select the desired range setting, "1" being closest to sensor and "10" being farthest away.
- 5) Once range is selected allow approximately 4 seconds to pass and then the display will go back to bottle counter and be in run mode.
- 6) Test bottle filler by placing bottle or hand in front of sensor to make sure water is dispensed.

SETTING UNIT TYPE

- 1) Depress the program button for approximately 2 seconds until the display changes then release. The display will change and scroll through two messages:
"RST FLTR" – Reset Filter Status LED
"SETTINGS" – System Settings Sub Menu
If the program button is not pushed again the display will scroll through the two messages above for three cycles and then default back to bottle count and be back in run mode.

Continued from below:

- 2) When the display changes to "SETTINGS", depress the button again. The display will change to show
"RNG SET" - Range set for IR sensor.
"UNIT TYP" - Type of unit (REFRIG or NON-RFRG)
"FLT SIZE" - Select filter capacity
"RST BCNT" - Reset bottle count
- 3) When display shows "UNIT TYPE" push program button once the display will show current value. Can be REFRIG or NON-RFRG
- 4) Push button once to change value. Once value is selected the display will show the new value. (Can be REFRIG or NON-RFRG)
"REFRIG" - stands for refrigerated product. In this setting the flow rate is estimated at 1.0 gallon per minute.
"NON-RFRG" - stands for nonrefrigerated product. In this setting the flow rate is estimated at 1.5 gallons per minute. Both "REFRIG" and "NON-RFRG" simulate 1 bottle equal to 20 oz.
- 5) Allow approximately 4 seconds to pass and the display will return to bottle counter and be in run mode.

RESETTING BOTTLE COUNT

- 1) Depress the program button for approximately 2 seconds until the display changes then release. The display will change and scroll through two messages:
"RST FLTR" – Reset Filter Status LED
"SETTINGS" – System Settings Sub Menu
If the program button is not pushed again the display will scroll through the two messages above for three cycles and then default back to bottle count and be back in run mode.
- 2) When the display changes to "SETTINGS", depress the button again. The display will change to show:
"RNG SET"- Range set for IR sensor.
"UNIT TYP" - Type of unit (REFRIG or NON-RFRG)
"FLT SIZE" - Select filter capacity
"RST BCNT" - Reset bottle count
If the button is not pushed again the display will scroll through the four messages above for three cycles and return to run mode.
- 3) When display shows "RST BCNT" push program button once the display will show current value, e.g. "0033183".
- 4) Once display shows current value push the program button once more to reset back to 0. The display will show BTLCT = 0 for approximately 2 seconds and then return to run mode showing 00000000 bottles.
NOTE: Once the bottle count is reset to zero there is no way to return to the previous bottle count.
- 5) Testing the bottle counter:
REFRIG units: Place bottle or hand in front of sensor for approximately 9 seconds to see bottle counter count 00000001,
(This is based on filling a 20 oz. bottle).
NON-RFRG units: Place bottle or hand in front of sensor for approximately 6 seconds to see bottle counter count 00000001,
(This is based on filling a 20 oz bottle).

SETTING FILTER CAPACITY

- 1) Depress the program button for approximately 2 seconds until the display changes then release. The display will change and scroll through two messages:
"RST FLTR" – Reset Filter Status LED
"SETTINGS" – System Settings Sub Menu
If the program button is not pushed again the display will scroll through the two messages above for three cycles and then default back to bottle count and be back in run mode.
- 2) When the display changes to "SETTINGS", depress the button again. The display will change to show:
"RNG SET"- Range set for IR sensor.
"UNIT TYP" - Type of unit (REFRIG or NON-RFRG)
"FLT SIZE" - Select filter capacity
"RST BCNT" - Reset bottle count
If the button is not pushed again the display will scroll through the four messages above for three cycles and return to run mode.
- 3) When display shows "FLT SIZE" push program button once. The display will show current value. Can be 3000GAL or 6000GAL.
- 4) Push program button again to display the desired "FLT SIZE".
- 5) Allow approximately 4 seconds to pass and the display will return to bottle counter and be in run mode.

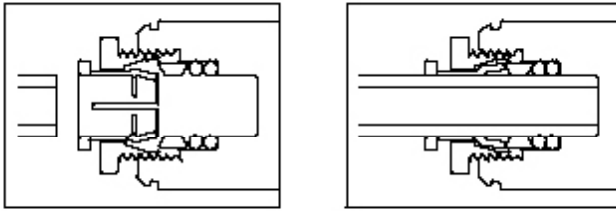

Note: Screw the locknut hand tight to seal

Figure 9

OPERATION OF QUICK CONNECT FITTINGS

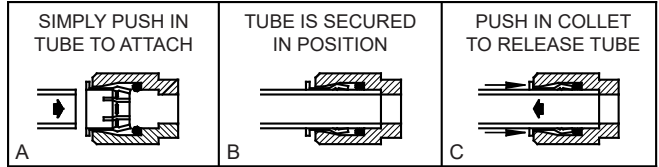

PUSHING TUBE IN BEFORE PULLING IT OUT HELPS TO RELEASE TUBE

Figure 10

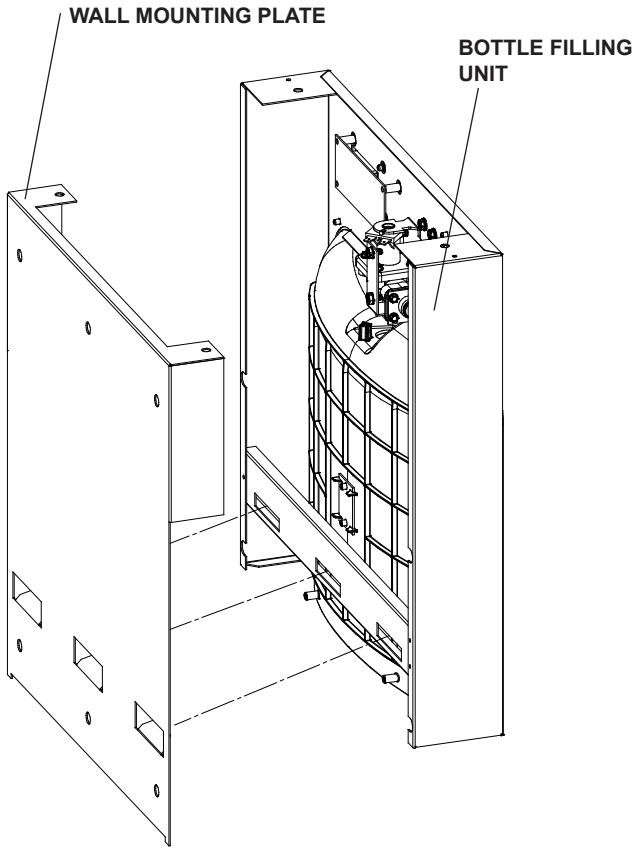
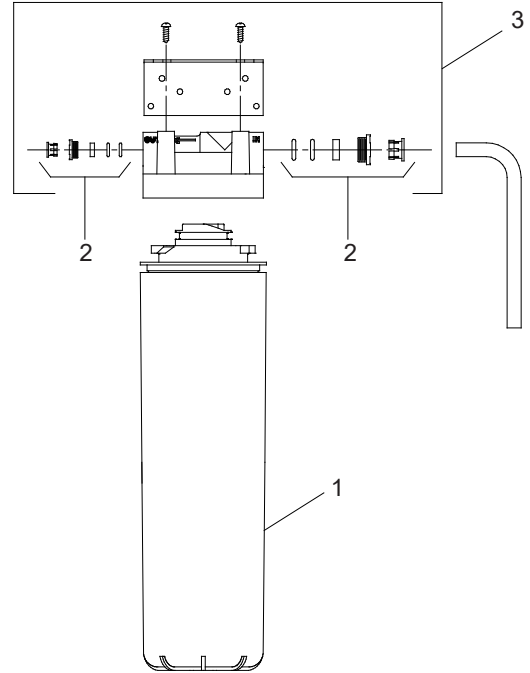

Figure 11



WATERSENTRY® Filter Detail

WATERSENTRY® FILTER PARTS LIST		
ITEM NO.	PART NO.	DESCRIPTION
1	51300C	Filter Assy-3000 Gal.
2	98926C	Kit-Filter Head Fitting Includes John Guest Fittings
3	0000000746	Assy-Filter & Bracket includes Filter Head/Mounting Bracket/John Guest Fittings/Screws

Fig.12

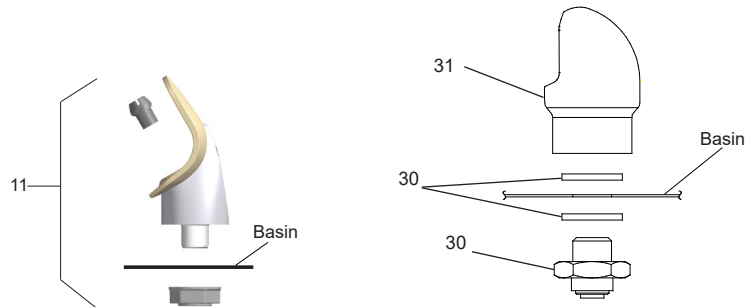

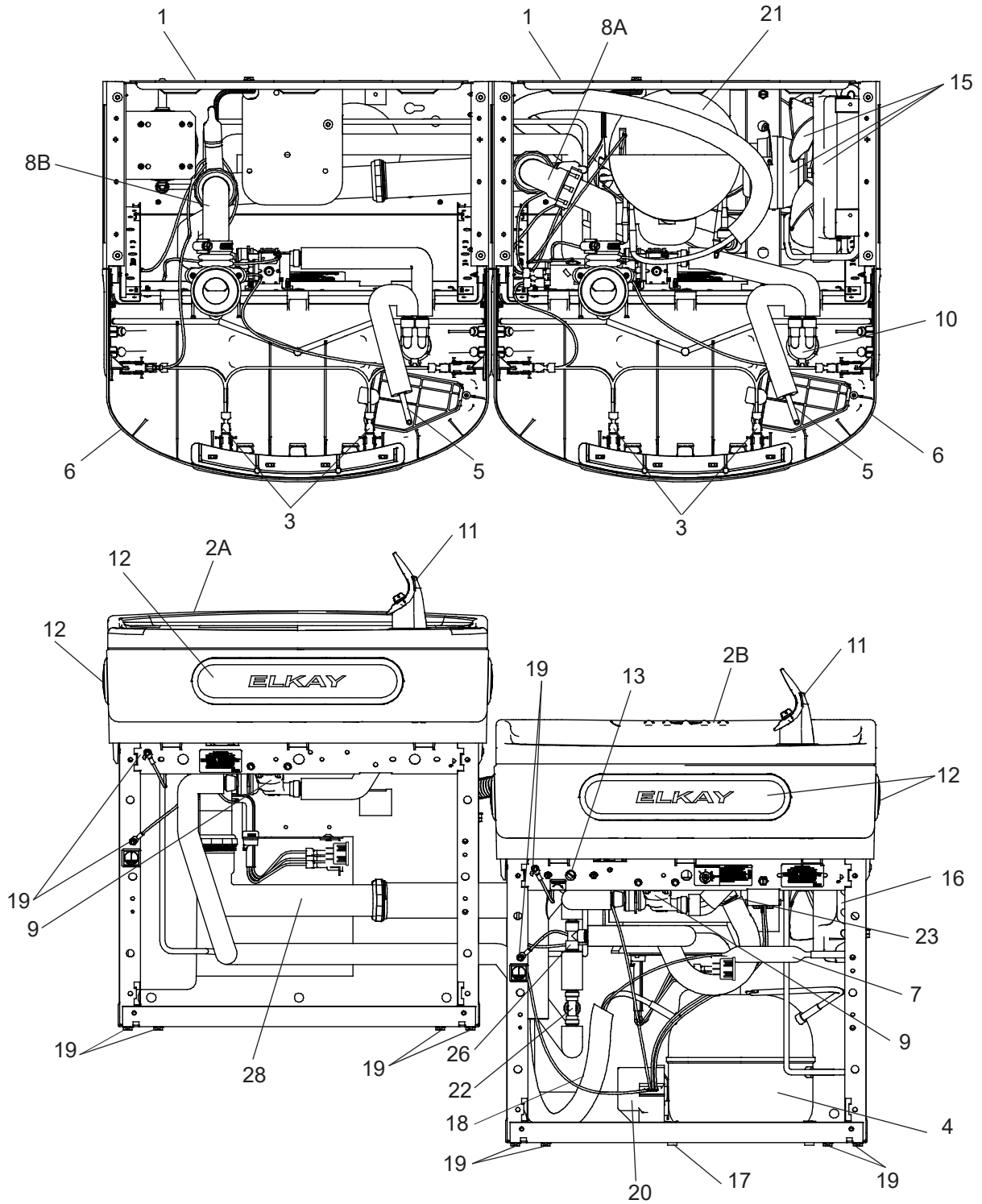

*Unit is pictured without bottle filler for clarity.

Replacement Parts: 230V Parts List

ITEM NO.	PART NO.	DESCRIPTION
1	28401C	Hanger Bracket
2A	55001109	Basin - Stainless Steel
2B	0000001337	Basin - Stainless Steel (BF)
3	36216C	Wiring - Front/Side Push Bar
*4	1000002147	Compressor Serv. Pak
5	56092C	Tube - Poly (Cut To Length)
6	56229C	Assy - Shroud - Upper (Front Side Push)
7	66703C	Drier
8A	1000004984	Kit - Drain Replacement EZTL8 (Brkt, Tube, Ftg, Clamp)
8B	97969C	Kit - Drain Replacement EZTLD (BF) (Brkt, Tube, Ftg, Clamp)
9	1000004575	Kit - Solenoid Valve/Regulator Assy
10	1000004564	Kit - Regulator w/Holder & Nut
11	56073C	Kit - Flexi Bubbler"O"-Ring/Nut
12	98734C	Kit - Pushbar (Front/Side) EZSTL
	1000001600	Kit - Pushbar (Front)
13	98773C	Kit - Cold Control/Screws
14	36066C	Internal Power Cord
15	0000000245	Kit - Fan Motor Assy/Blade/Motor/Shroud/Screws/Nut
16	98776C	Kit - Condenser/Drier
17	98777C	Kit- Compr Mtg Hdwe/Grommets/Clips/Studs
18	98778C	Kit - Heatx/Drier
19	98898C	Kit - Hardware (EZ)
20	98751C	Kit - Relay/Cvr/Overload
21	98724C	Kit - Evaporator Assembly
22	1000002062	Kit - Tee 1/4" x 1/4" x 3/8" (3 Pack)
23	1000001602	Kit - 75583C Elbow 5/16" x 1/4" (3 Pack)
24	36299C	Jumper Wire (Purple)
25	0000001339	Ferrule - Drain (BF)
26	1000001994	Kit - 70682C 1/4" Tee (3 Pack)
27	1000001812	Kit - Bottle Filler Drain
28	1000004447	Wasteline Drain Assy
29	36067C	Internal Power Cord Non-Refrigerated
30	1000001791	Kit - VR Bubbler Nipple & Gaskets
31	97446C	Kit - VR Bubbler
NS	35826C	Inlet Power
NS	1000000888	Kit - EZTL Wrapper/Serv Label - Stainless (R)
NS	1000000944	Kit - EZTL Wrapper/Serv Label - Light Grey (R)
NS	1000000758	Kit - EZTLD Wrapper/Serv Label - Stainless (L)
NS	1000000759	Kit - EZTLD Wrapper/Serv Label - Light Grey (L)
NS	36300C	Jumper Wire (Yellow)
NS	36004C	Jumper Wire
NS	28025C	Wrapper - Filler Stainless
NS	28024C	Wrapper - Filler Light Grey
NS	28030C	Bracket - Power Inlet

NS = NOT SHOWN

*Includes Relay & Overload. If under Warranty, replace with same Compressor used in original assembly.

NOTE: All correspondence pertaining to any of the above water cooler or orders for repair parts MUST include Model number and Serial number of cooler, name and part number of replacement part.

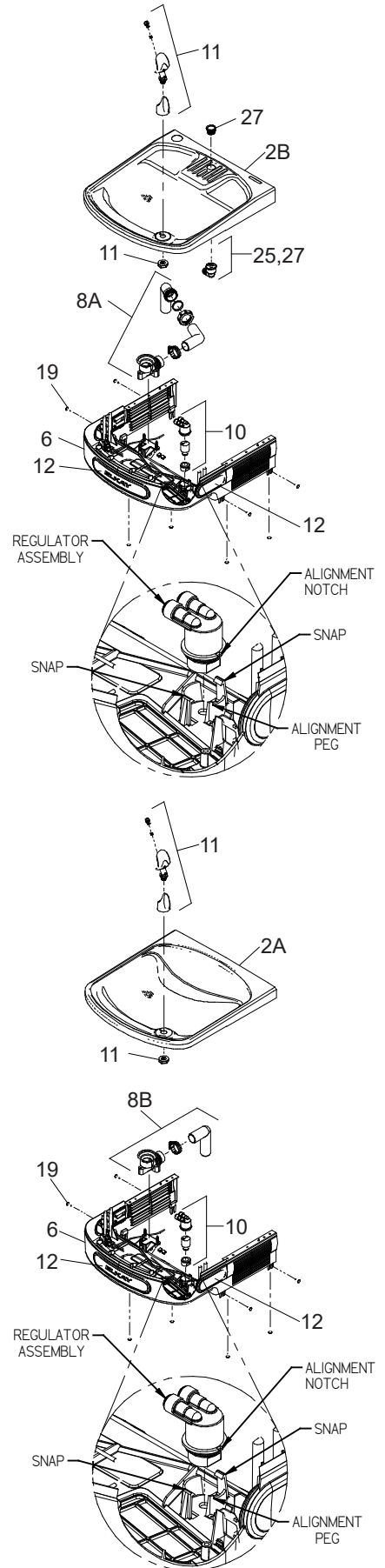

Replacement Parts: Bottle Filler Parts List

ITEM NO.	PART NO.	DESCRIPTION
NS	98631C	Kit - Electrical Package-230V
NS	98544C	Kit - IR Sensor
NS	1000004574	Kit - BF Solenoid Valve Replacement-230V
NS	98546C	Kit - Aerator Replacement
32	98547C	Kit - Top Cover Replacement
NS	98549C	Kit - Hardware & Waterway Parts
NS	98551C	Kit - Filter Mounting Cover
NS	98552C	Kit - Retro Filter Mounting
NS	1000001813	Kit - Tower/Basin Gasket

For Replacement Parts, contact your local distributor or call 1.800.834.4816

Elkay Manufacturing Co. 2222 Camden Court – Oak Brook, IL 60523 U.S.A – 630.574.8484

INSTRUCTIONS TO MOVE THE BOTTLE FILLER & BASIN TO THE LEFT SIDE (NON-REFRIGERATED) FOR ALTERNATE MOUNTING VERSATILE BI-LEVEL



WARNING:
Disconnect electrical power.

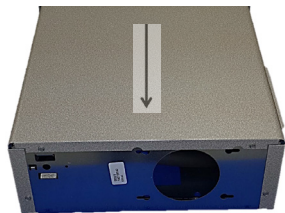

Using a 5/16" socket, remove the (4) screws from the bottom of each cooler to remove the wrappers.



Using a #T20 (6 point star bit), loosen the shroud screws. Both sides, both coolers.



ONLY move the filler panel and j-clip to the refrigerated (right) side if right side will be mounted 'high'.

Refrigerated Cooler side:

Carefully lift and tip the shroud/basin assembly off of the cooler frame.

Only disconnect the (2) black wires coming from the shroud assembly that go to the solenoid valve and to the cold control.

Disconnect the water line at the solenoid valve. Reference (Fig. 16, p.17) for the operation of the quick connect fittings.

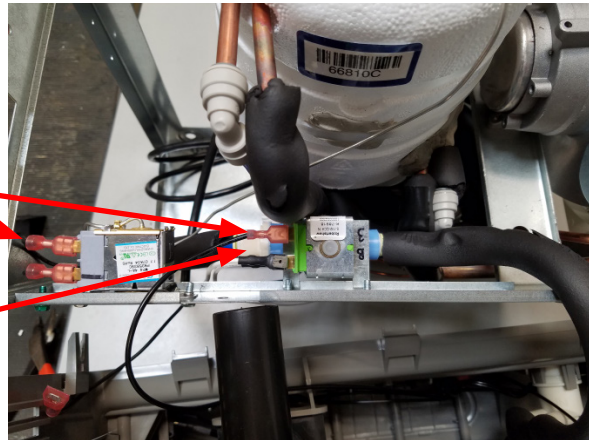

Non-Refrigerated Cooler side:

Carefully lift and tip the shroud/basin assembly off of the cooler frame.

Only disconnect the (2) black wires coming from the shroud assembly going to the solenoid valve and to the power cord.

Disconnect the water line at the solenoid valve. Reference (Fig. 16, p.17) for the operation of the quick connect fittings.

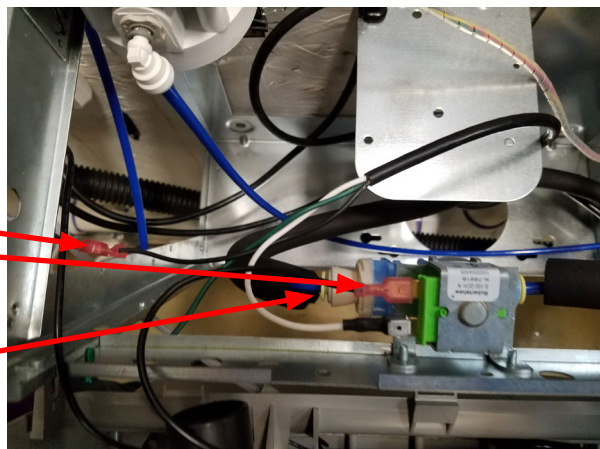

INSTRUCTIONS CONTINUED.....



Swap drain parts in shroud:

Loosen each hose clamp retaining the drain pieces.

Remove each drain piece and swap to other basin.

Tighten each hose clamp.

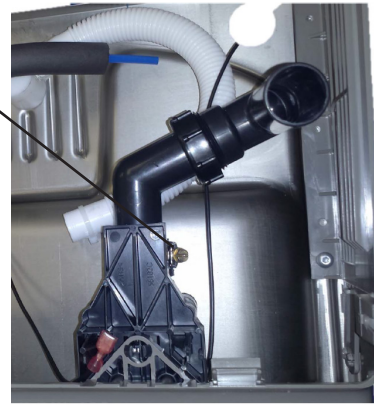

Refrigerated Cooler side:

Carefully lift and tip the shroud/basin assembly off of the cooler frame.

Only disconnect the (2) black wires coming from the shroud assembly that go to the solenoid valve and to the cold control.

Disconnect the water line at the solenoid valve. Reference (Fig. 10, p.8) for the operation of the quick connect fittings.

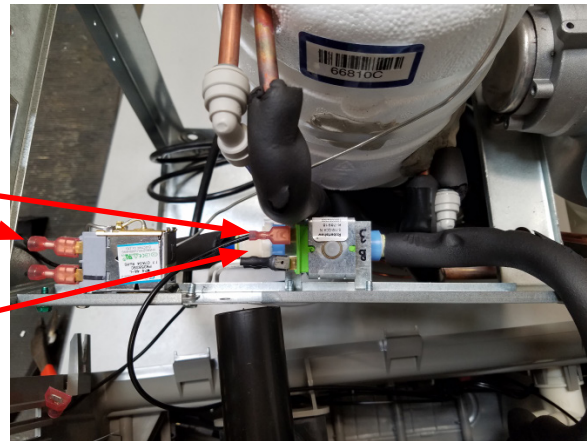

Non-Refrigerated Cooler side:

Carefully tip the shroud/basin assembly toward the cooler frame.

Connect one of the black wires to the solenoid valve and one to the power cord.

Re-connect the water line at the solenoid. Reference (Fig. 10, p.8) for the operation of the quick connect fittings.

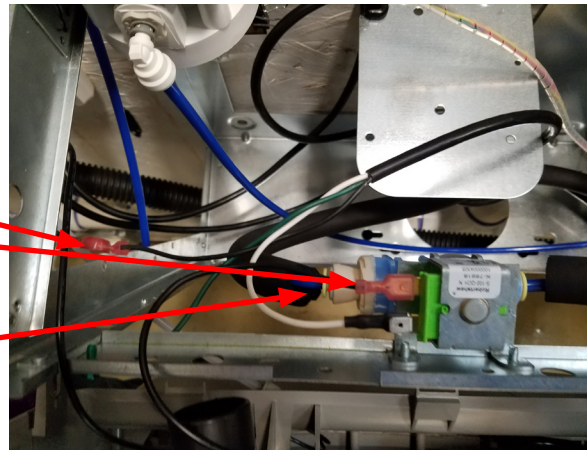

Precautions need to be taken when replacing the Basin/shroud assembly:

- 1) Make sure all wires are inside frames so as not to become pinched.
- 2) Water line coming from bottle filter drain must be pulled down as not to interfere with the fan operation. The fan blade needs to spin freely.



Using a #T20 (6 point star bit), tighten the shroud screws. Both sides, both coolers, being careful not to overtighten.

INSTALL WRAPPERS & TRIM STRIPS PER PAGE 13

SEE PAGE 14 FOR PLUMBING DIAGRAMS

Versatile Wrapper and Trim Kit Installation Instructions

Left Hand Wrapper (High Side)

- 1) Remove existing wrapper by removing the (4) screws from bottom.
- 2) Screw trim piece to wrapper with (2) screws (provided)
- 3) Re-install wrapper with (4) screws.
- 4) Dispose of unused cover plate.

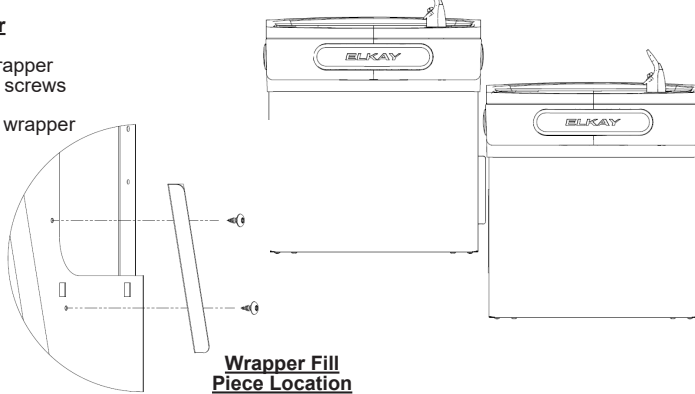

Wrapper Fill Piece Location (Left Side High)

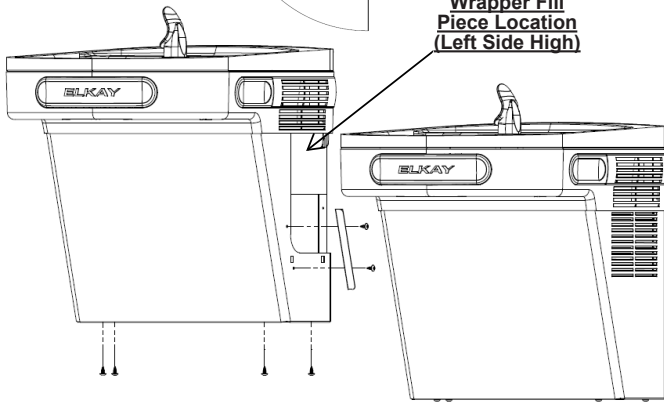

Right Hand Wrapper (Low Side)

- 1) Remove existing wrapper by removing the (4) screws from bottom.
- 2) Clip cover plate, sliding until plate sits flush with the wall.
- 3) Re-install wrapper with (4) screws.
- 4) Dispose of unused trim piece.

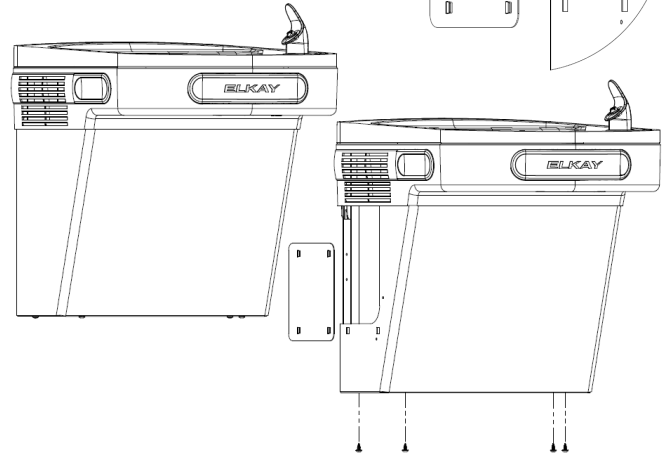
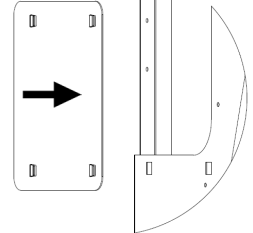

Left Hand Wrapper (Low Side)

- 1) Remove existing wrapper by removing the (4) screws from bottom.
- 2) Clip cover plate, sliding until plate sits flush with the wall.
- 3) Re-install wrapper with (4) screws.
- 4) Dispose of unused trim piece.

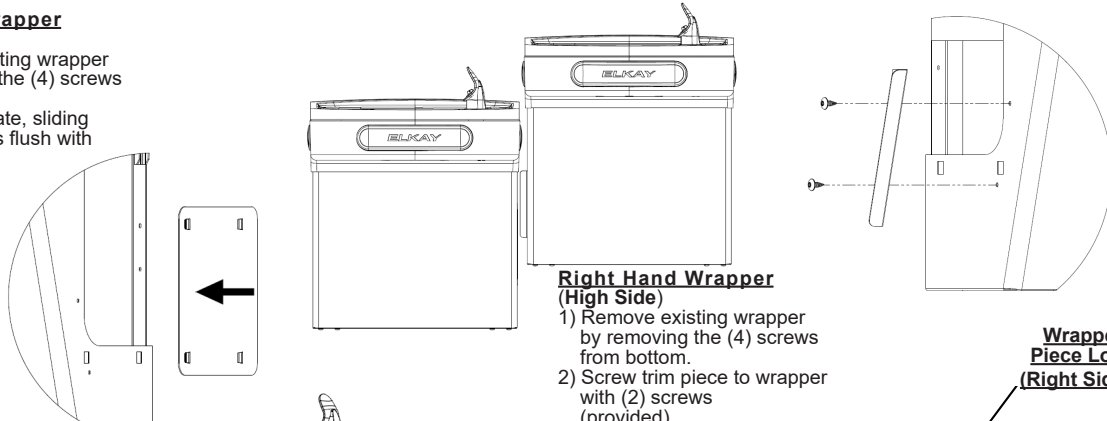

Right Hand Wrapper (High Side)

- 1) Remove existing wrapper by removing the (4) screws from bottom.
- 2) Screw trim piece to wrapper with (2) screws (provided)
- 3) Re-install wrapper with (4) screws.
- 4) Dispose of unused cover plate.

Wrapper Fill Piece Location (Right Side High)

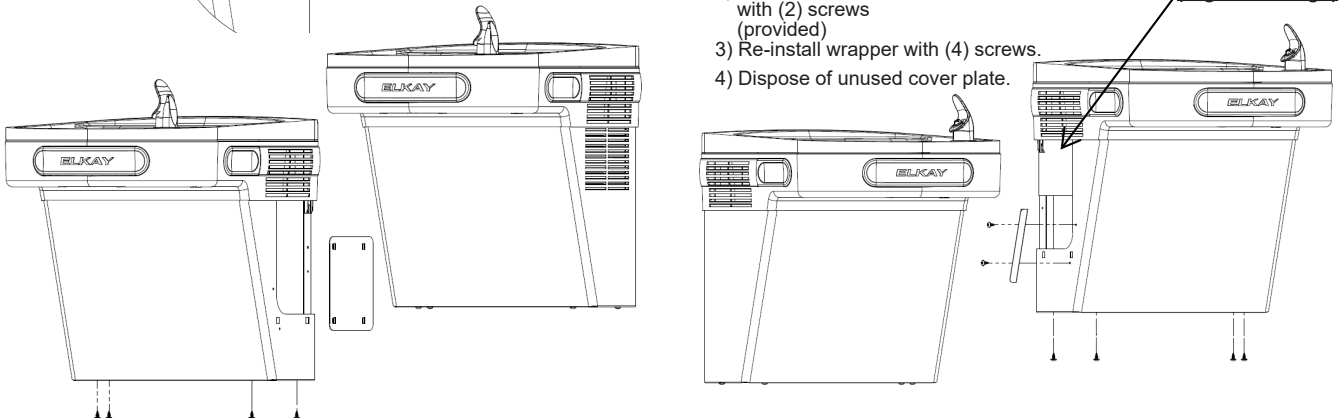

PLUMBING DIAGRAMS VERSATILE BI-LEVEL

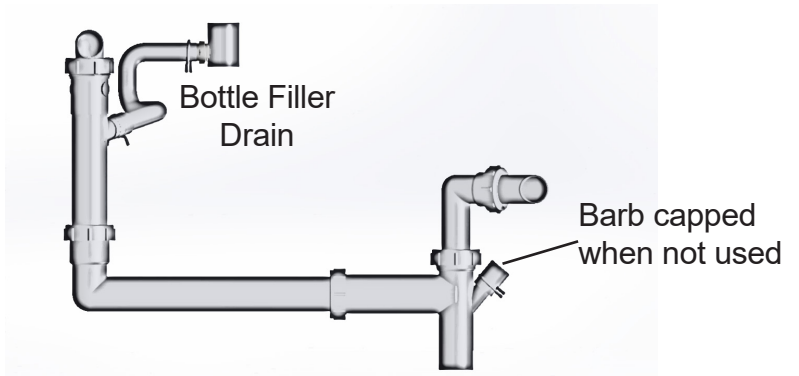
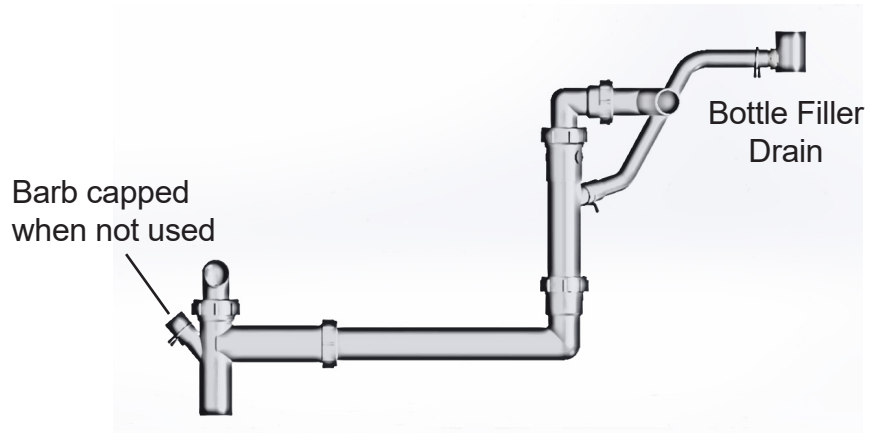
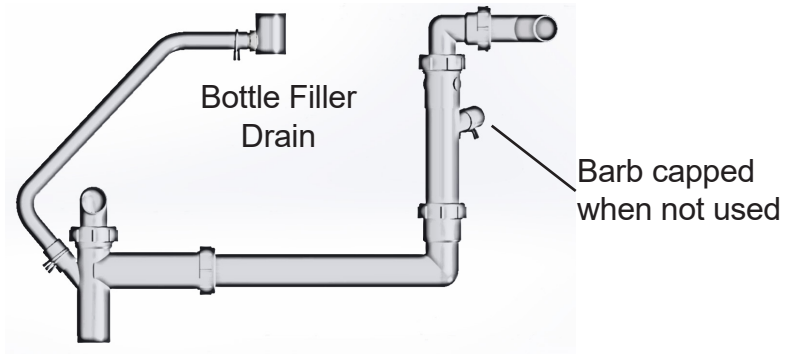
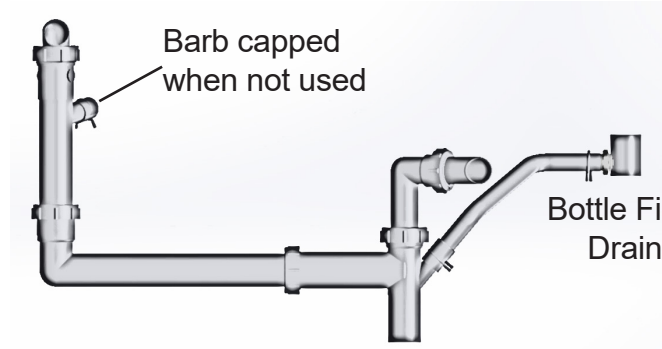

PLUMBING DIAGRAMS FOR EZ BI-LEVEL COOLERS

Standard EZ Bi-Level Pressurized Plumbing Diagram

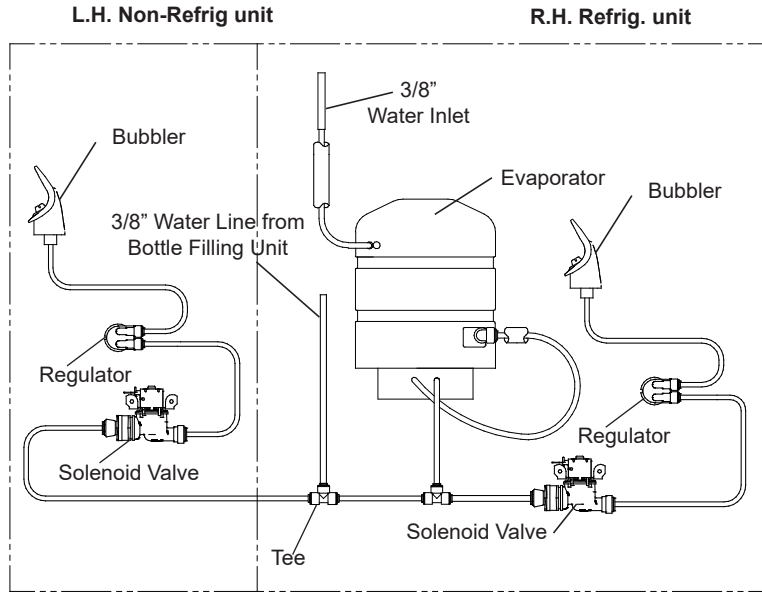

EZ Bi-Level Plumbing Diagram after Filter Installation & Bottle Filler Water Line Addition

