



The Elkay EZH20® Auto-Sensor chilled bottle refill station is distinguished by its space-saving design and auto-sensor technology.

The unit quickly delivers fresh drinking water through an anti-microbial bottle refill nozzle whilst enhancing sustainability by reducing the user's dependency on disposable plastic bottles. The sanitary no-touch activation sensor has a 20 second shut off time, while the Green Ticker counts the number of bottles saved from waste.

The EZH20 Auto-Sensor is the ideal product for architectural interiors, delivering chilled water for users on the go.

Product features

- One anti-microbial bottle refill nozzle
- Refrigerated water
- Fully recessed in-wall design
- Stainless steel construction
- Sanitary no-touch auto sensor activation
- Quick fill rate
- Wheelchair accessible
- Drainage system to prevent stagnant water build up
- Up to five year warranty*



Technical Details

Material & Finish	Stainless steel
Power	230V/50Hz
Mounting option	Wall-mounted (in wall frame plate)
Chilling option	Refrigerated
Filter option	5 micron Filter
Dimensions	L: 50.2cm W: 8.9cm H: 103.7cm
Approx. Shipping weight	36 kgs

*A full 5-year warranty on the compressor and hermetically sealed refrigeration systems, and 24-month parts and labour warranty on all other components

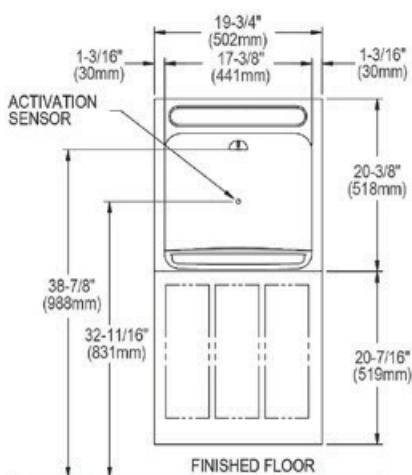

Front view

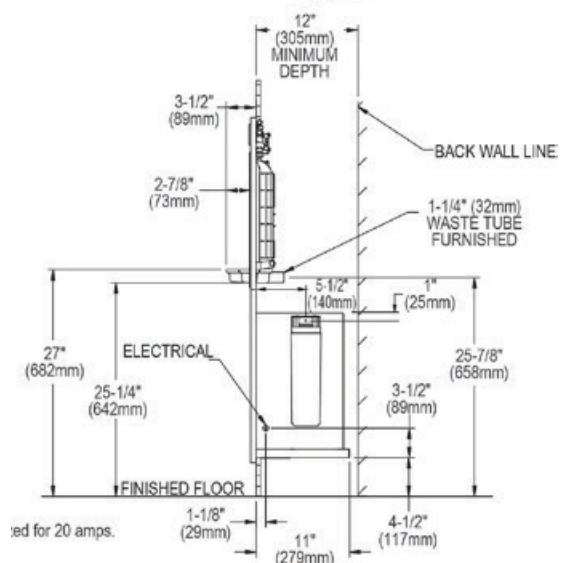

Side view