

SCHWAN INSTALLATION GUIDE

For Schwan Versatap SC52E

versatap™
MUCH MORE THAN A MIXER



SCHWAN[®]
Instant **Hot** **Cold** Filtered Water

FOR SERVICE OR ASSISTANCE CALL MERQUIP ON 0800 636 0 636.

Schwan recommends that a qualified tradesperson installs your Schwan system.

IMPORTANT INFORMATION AND SAFETY INSTRUCTIONS

PLEASE READ ALL INSTRUCTIONS CAREFULLY

When installing and using all electrical appliances, basic safety precautions should always be followed including the following:



ELECTRIC SHOCK HAZARD

- To prevent electric shock, do not place cord, plugs or appliance in water or other liquid.
- Do not operate any appliance with a damaged cord, plug, or after the appliance malfunctions.
- If the supply cord is damaged, it must be replaced by the manufacturer, its service agent or similarly qualified persons in order to avoid a hazard.
- Do not attempt to service this product. Repairs should be done by authorized service personnel.
- Do not use outdoors or in damp areas.



FIRE HAZARD

- When installing the appliance, allow a minimum airspace of 100mm around the front, sides, and top of the boiler tank for air circulation.



PERSONAL INJURY

- This appliance is not intended for use by persons (including children) with reduced physical, sensory or mental capabilities, or lack of experience and knowledge, unless they have been given supervision or instruction concerning use of the appliance by a person responsible for their safety.
- Children should be supervised to ensure that they do not play with the appliance.
- This appliance is intended for use in household and similar applications, such as light commercial (up to 6 staff), the hospitality industry, and related residential type environments.

SPECIFICATIONS

VOLTAGE: 230V ~50Hz

POWER INPUT: 1300W

TANK CAPACITY: 2.4 L

MINIMUM INLET WATER

PRESSURE: 240 kpa

MAXIMUM INLET WATER

PRESSURE: 700kPa

COMPLIES WITH:

AS/NZS 60335.1 and

AS/NZS 60335.2.15

INSTALLATION PRE-REQUIREMENTS

Power supply

- A standard 10amp 3pin power outlet conveniently placed within 1m of the intended location of the boiler tank. This must be installed by a qualified electrician.

Water supply

- A standard Cold water supply fitted with a 15mm stop tap situated within easy access of the intended location of the boiler tank. This must be installed by a qualified plumber.
- Supply water pressure must not exceed 1000kpa with pressure regulator installed.
- Water supply must be microbiologically safe.



PROPERTY DAMAGE

- In situations where any water leakage could result in damage to property, the complete Schwan Installation should be installed over a **Drained Safe Tray**, plumbed to an appropriate drain.

Component Checklist

Main Components

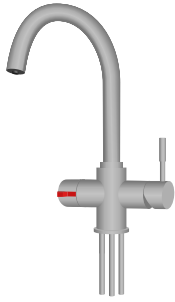

Schwan Dispenser



Schwan Boiling Tank



Schwan Filter System

Fitting Kit



10mm x 600mm
Food Grade Nylon Tubing



Filter Fixing Screws x 4



Apex-FM 350 Pressure Regulator

TYPICAL INSTALLATION LAY OUT

- Allow a minimum air space of 100mm around the front, sides, and top of the boiler tank. No clearance is required at the back of the boiler tank.
- Both the boiler tank and filter assembly must be situated within 600mm of the dispenser.
- The filter assembly must be easily accessible to allow for routine filter maintenance.

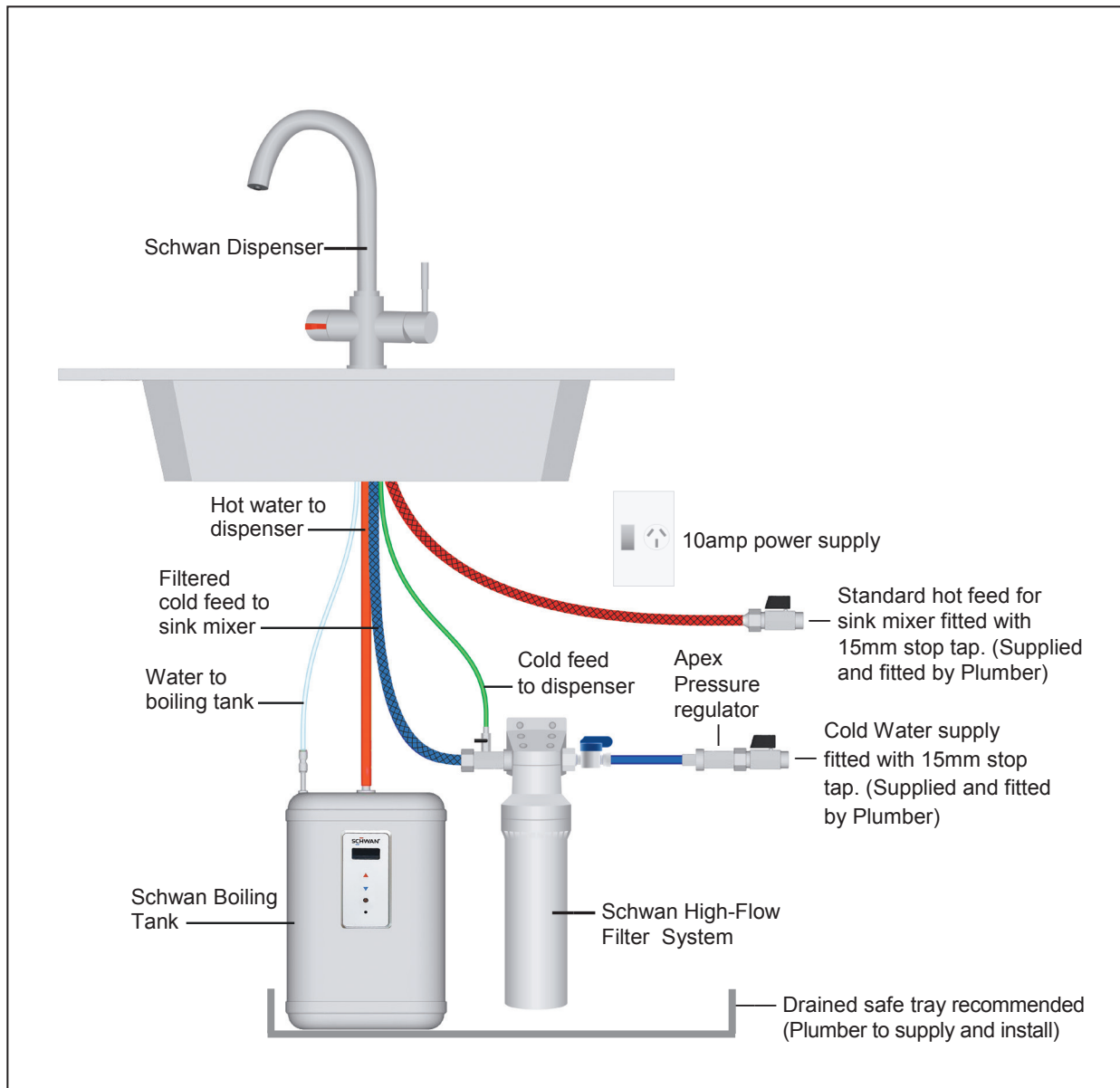

⚠️ WARNING In situations where any water leakage could result in damage to property, the complete Schwan installation should be installed over a Drained Safe Tray, plumbed to an appropriate drainage connection.

DIAGRAM 1

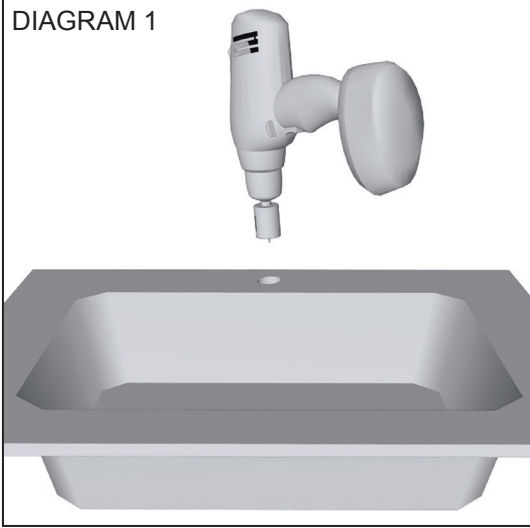

DRILL 35MM HOLE FOR DISPENSER

- You will need to drill a 35mm diameter hole in the bench top or sink insert where you would like to place the dispenser.
- The dispenser must be within 600mm of the proposed location of the Schwan under bench boiling tank, and filter system. (Ref Diagrams 2 and 7)
- A clearance of 75mm is required from the centre of the tap hole to the wall or splashback behind the tap.

DIAGRAM 2

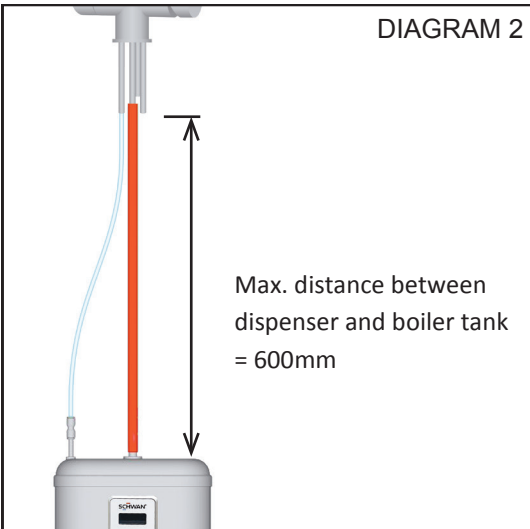

WARNING In situations where any water leakage could result in damage to property, the complete Schwan Installation should be installed over a Drained Safe Tray, plumbed to an appropriate drain .

INSTALL THE BOILING TANK

- The boiling tank must be installed below the dispenser.
- The boiling tank must be mounted vertically.
- **The** boiler tank may be wall or floor mounted inside the cabinet within 600mm of the dispenser. (Ref. Diagram 2)

DIAGRAM 3

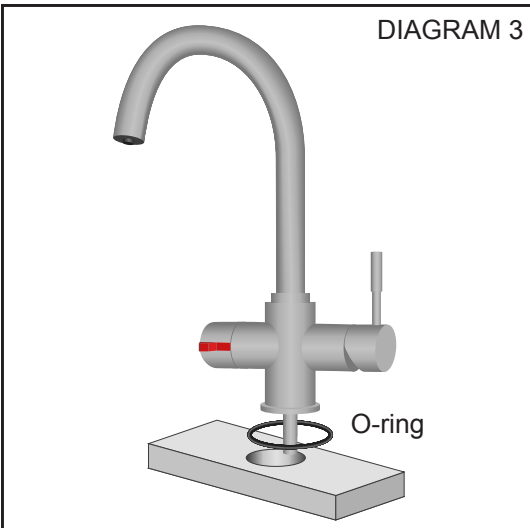

- Connect all the tubing to the sink mixer first.
- Position the o-ring under the faucet base.
- Insert all tubing through the 35mm hole and lower the faucet into position.

DIAGRAM 4

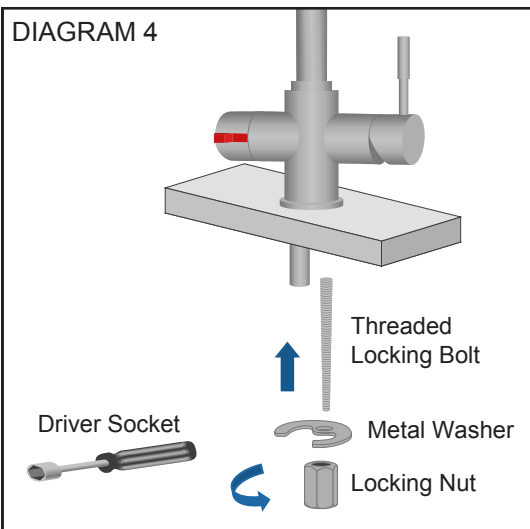

- Use the driver socket to tighten the locking nut.

DIAGRAM 5

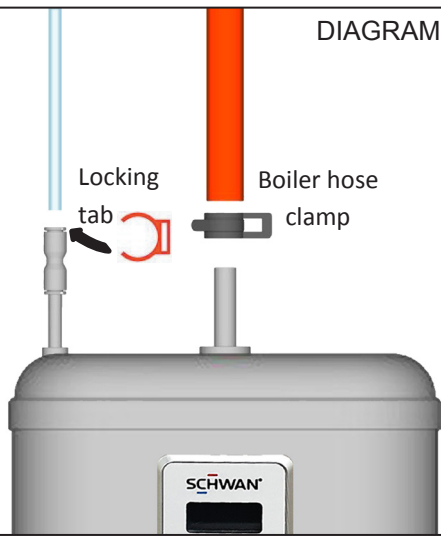

DISPENSER / BOILING TANK CONNECTION

WATER SUPPLY TO BOILER – (Green 6mm tube.)

- Remove red locking tab from the top of the push-lock fitting located at the top left of the boiling tank and firmly insert the 6mm tube into the push-lock fitting, pull back to ensure it is locked into position, and refit the locking tab.

HOT WATER FROM BOILER – (Red label 12mm silicone tube)

- Connect the large clear silicon tube to the central outlet located in the top of the boiling tank and secure with hose clamp supplied. (Ref. Diagram 5)

DIAGRAM 6

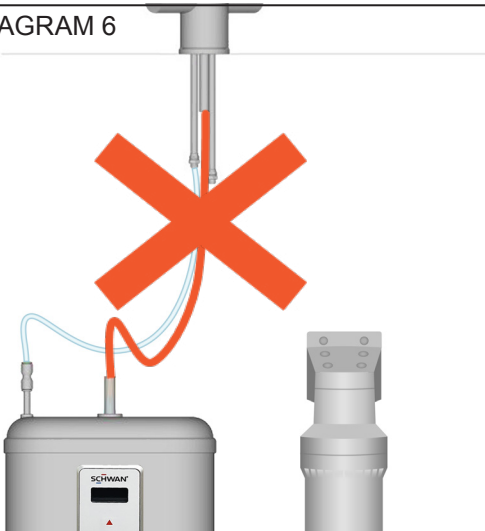

- The end of the 6mm tube must be cut clean and square.
- Be sure the hoses are not kinked or twisted.
- Tubes must be cut to a convenient length to avoid sagging but must not be stretched taut. (Ref. Diagram 6)

DIAGRAM 7

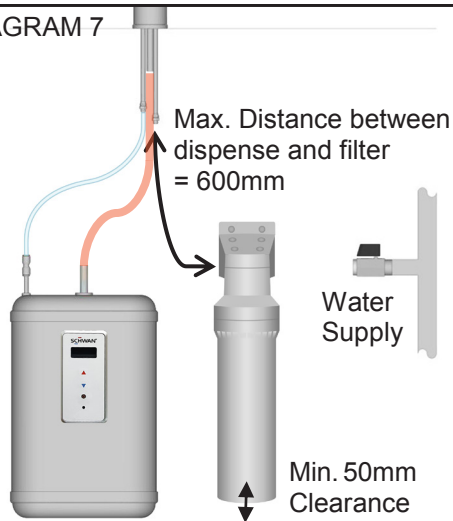

INSTALLING THE FILTER SYSTEM



- The filter must be within 600mm of the dispenser
- The filter must be installed vertically.
- Allow at least 50mm of clearance below the bottom of the filter so the filter cartridge can be easily removed for servicing. (Ref. Diagram 7)

DIAGRAM 8

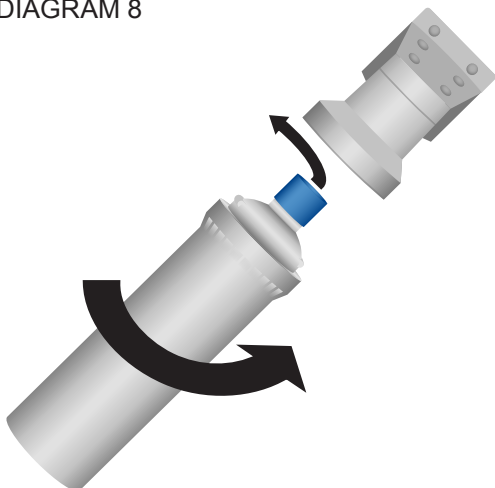

- Remove and discard blue cap from filter cartridge and fit to filter head (Ref. Diagram 8)

DIAGRAM 9

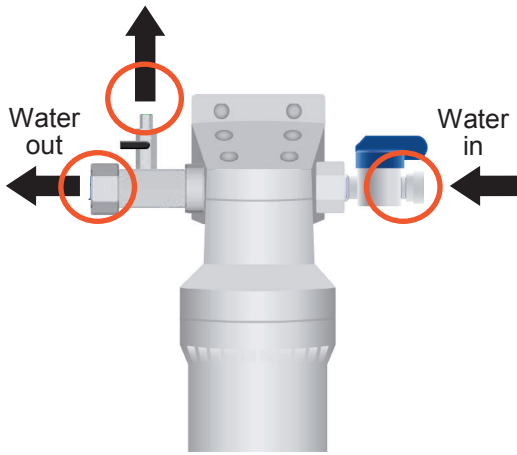

- Fix filter to the wall of the cabinet using screws supplied



- The direction of the water flow through the filter is important so check the labelling on the filter head and consider this when configuring the layout of the under bench components. (Ref. Diagram 9)

DIAGRAM 10

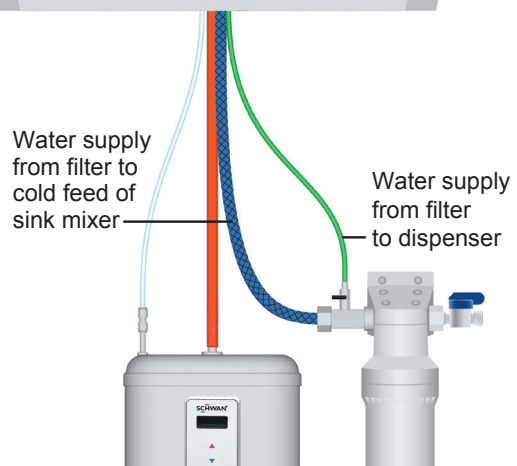

CONNECT DISPENSER TO FILTER

- Connect green 6mm nylon hose to the 6mm fitting at the outlet side of the filter head. (Ref. Diagram 10)
- The end of the 6mm tube must be cut clean and square, and inserted firmly into the push lock fitting then pulled back to ensure it is locked into position.

DIAGRAM 11

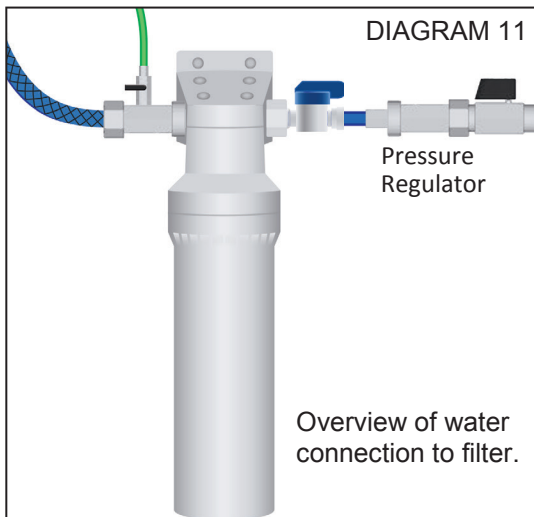

CONNECT WATER SUPPLY

Diagram 11 shows an overview of the water supply connection including the Pressure Regulator.



- The pressure regulator must be installed upstream (before) the filter assembly.
- Water flow must be in the direction indicated by the arrow on the side of the regulator.

DIAGRAM 12

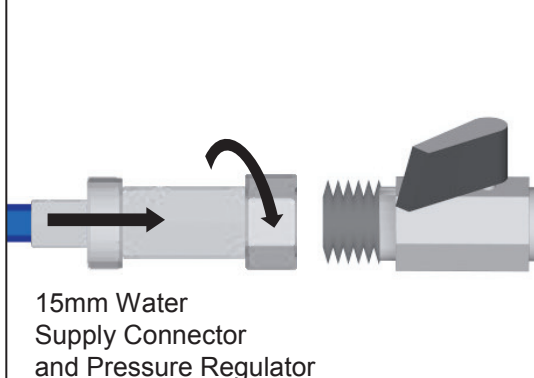

FIT 15MM WATER SUPPLY CONNECTOR

- Fit Apex PRV to water supply and tighten appropriately to ensure a good seal. (Ref. Diagram 12)

DIAGRAM 13

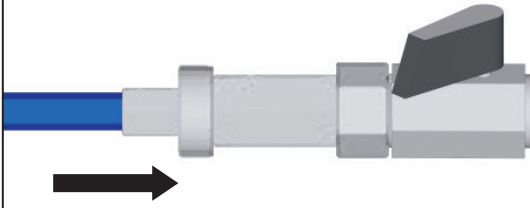

- Insert 10mm tube into the Apex PRV. (Ref. Diagram 13)

! IMPORTANT

- Tubing must not be kinked or twisted.
- Tubing should be cut to a convenient length but should not be stretched taut.
- Ensure all fittings and tube connections are protected against damage from objects stored in the cupboard.

DIAGRAM 14

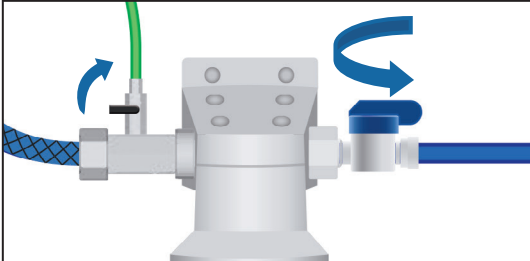
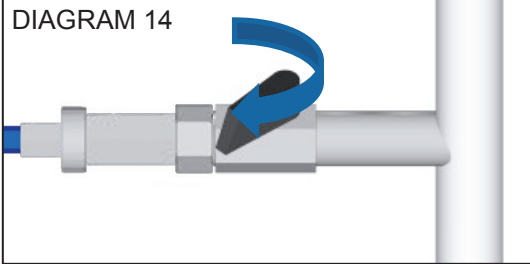

COMMISSIONING AND TESTING

! WARNING

DO NOT CONNECT TO POWER SUPPLY

- Turn on main water supply
- Turn on boiler tap water supply

DIAGRAM 15

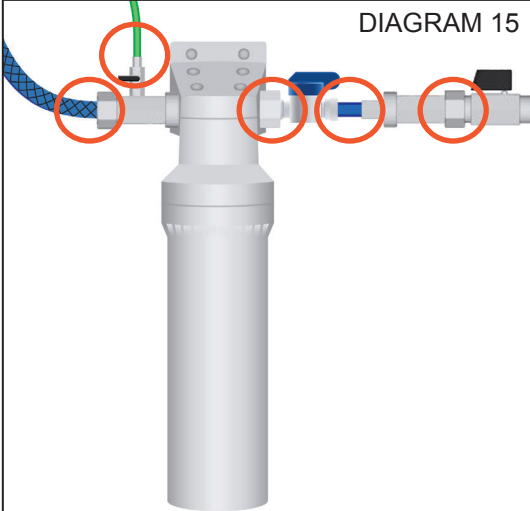

- Check all fittings and tube connections to and from the filter for water leakage.
- If any leaks are noted ensure they are repaired before moving onto the next step.

DIAGRAM 16

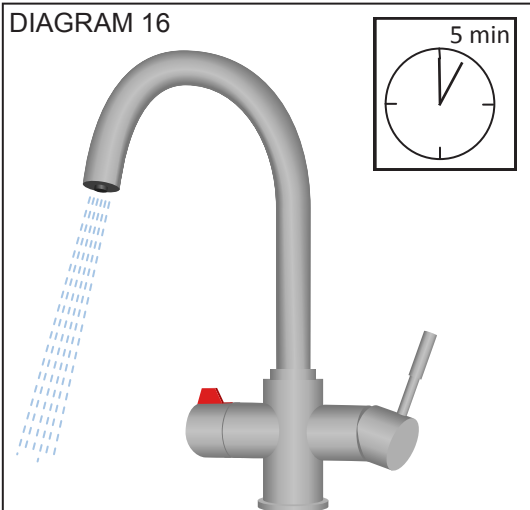

FLUSHING THE FILTER

- Turn on the cold sink mixer water
- Leave to run for 5 minutes to flush and condition the filter

DIAGRAM 17

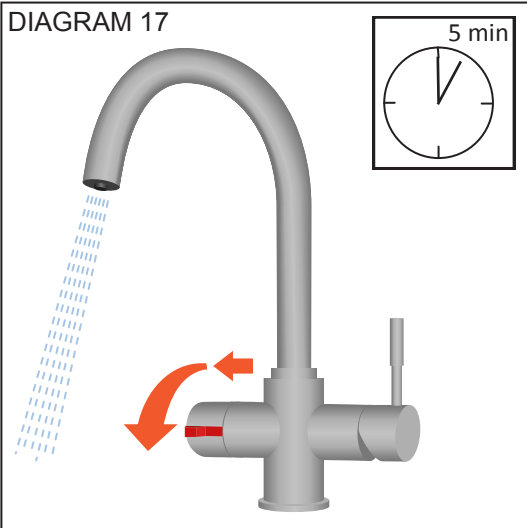

FILLING THE BOILING TANK

- Turn the hot tap on (Slide red button on tap left to release safety lock) (Ref. Diagram 17)
- The hot tank will begin to fill. There may be a delay of 1 – 2 minutes before water starts to flow from the dispenser.

8

DIAGRAM 18

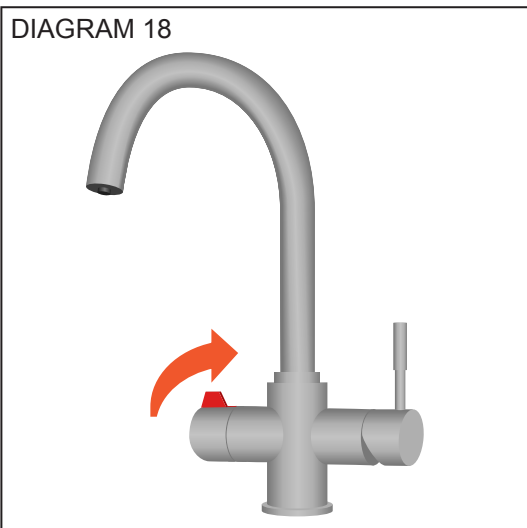

- Allow water to flow consistently and evenly from the dispenser for 2 minutes before turning off the hot water tap.

DIAGRAM 19

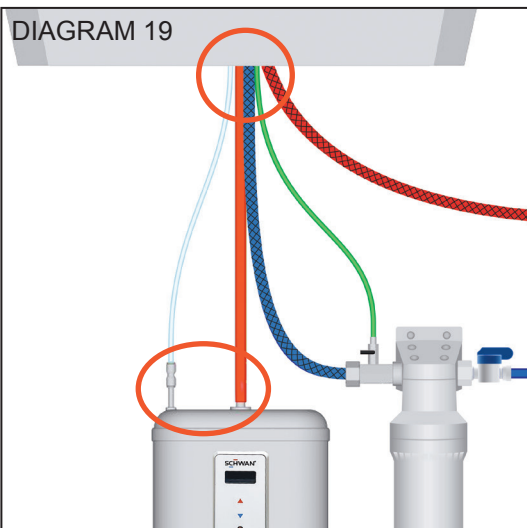

CHECK FOR LEAKS

- Check all fittings and tube connections to and from the boiling tank for water leakage. (Ref. Diagram 19)
- If any leaks are noted ensure they are repaired before moving onto the next step.

DIAGRAM 20

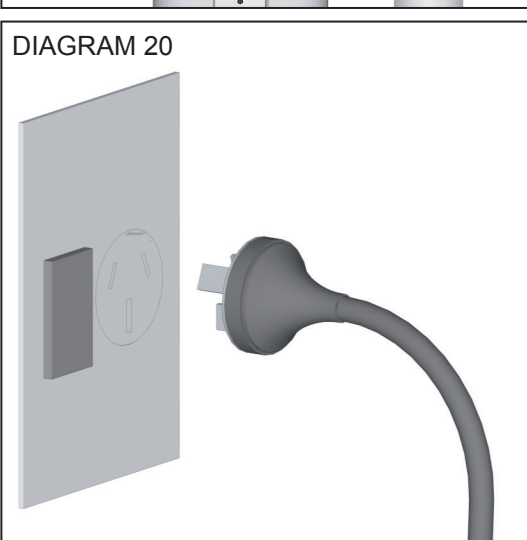

CONNECT TO POWER SUPPLY

- Plug power lead into power supply and switch on

9

COMMISSIONING AND ADJUSTING THE SCHWAN SYSTEM

Press the Power On/Off Button on the Control Panel to switch the unit on. The LCD Screen will light up, and the LED Indicator will glow.

Once the system is full of water and the power is turned on, it will start heating.

The LCD Screen on the front of the unit will show the current tank temperature by default.

Solid 'C' = Current Tank Temperature

Blinking 'C' = Set Temperature

For safety, your Schwan System has a maximum allowable setting of 98°C in the tank. It also comes pre-adjusted to 98°C to simplify installation set up.

Should you wish to adjust the temperature, simply press the up and down arrows on the front LCD Screen - the red 'C' will blink to show the desired set temperature. Once you have finished adjusting it, the screen reverts back to displaying the current tank temperature and the red 'C' will stay solid.

The LED Indicator will glow red when the unit is heating, and green when the unit is at temperature.

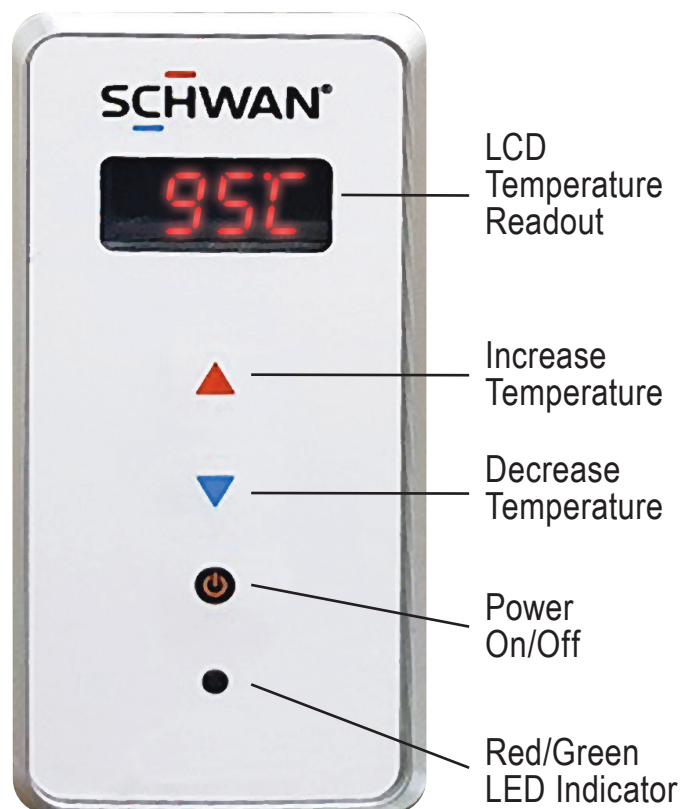

TROUBLESHOOTING

Important Note: The Schwan drinking water system is designed to dispense hot water at up to 97°C. The Schwan drinking water system is not designed to dispense physically boiling water (100°C)

WATER IS NOT HOT

(assuming cold water supply is connected properly and valve is open)

- Check that the power supply is live and that the circuit breaker has not tripped.
- Check if the boiling tank is plugged into the power supply and turned on.
- Adjust temperature setting on front of unit.
- Check the hot tank is full. (Ref. Diagrams 17 – 18)
- The self re-setting thermal fuse may have tripped. Unplug boiling tank from power supply and allow ½ hour to cool before restarting.

HOT WATER IS SPURTING OUT OF THE DISPENSER

- Check all tube connection are correct. (Ref. Diagrams 5 & 10)
- Check that the hose connecting the faucet to the dispenser tank is not clogged, twisted or kinked.

WATER FLOW DOES NOT START STRAIGHT AWAY

- A delay of 2 or 3 seconds is normal especially if your Schwan has not been used in the last hour or so. This is due to the efficient operation of the “expansion tank” within the boiling unit which protects against the risk of hot water dripping from the dispenser.
- Make sure all valves on water supply are open.
- Check the tubes from the dispenser for twisting or kinks.

EXCESSIVE STEAM APPEARS FROM THE DISPENSER SPOUT

- Lower temperature by adjusting on front of unit. Test setting and repeat adjustment if necessary.



SCALDING DANGER

Note: If lowering the thermostat setting does not stop the boiling, unplug the power supply cord and contact Merquip on 0800 636 0 636.

FOR SERVICE OR ASSISTANCE CALL MERQUIP 0800 636 0 636.