

HOME DATA SHEET

B5000 Sparkling MMT

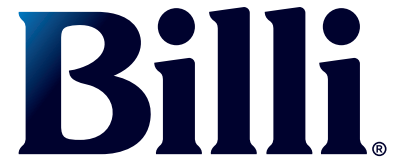

Billi B-5000 Sparking with Gooseneck Multifunction Mixer Tap

The B-5000 Sparkling system is the ultimate home water appliance. Delivering instant boiling, chilled filtered water, with the added luxury of sparkling filtered water.

The Good Design Award Winning Multifunction Mixer tap complements the space saving and multifunctional approach of Billi's Home Range of products perfectly, negating the requirement for an additional domestic supply mixer tap while providing a sleek solution to dispensing filtered water.

Supplied standard with 994052 sub-micron filtration from BWT to deliver the freshest tasting water and ensure the health of your family & guests.



Multifunction Mixer Tap





B5000 Sparkling Under-Bench Unit

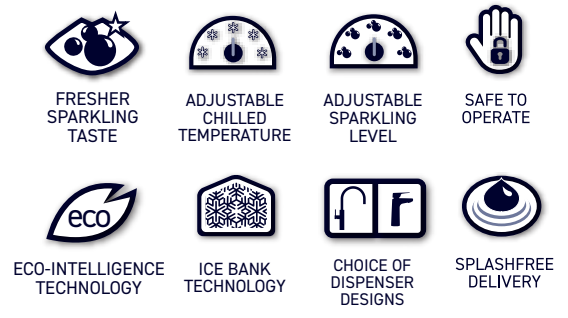

Features



PRODUCT SPECIFICATIONS

Water type	Product code	Model name	Dispenser	Power supply (amps)	Suggested usage
  BOILING CHILLED   SPARKLING FILTERED	915100G	B5000 Sparkling	Multifunction Mixer Tap	2x10	<ul style="list-style-type: none"> • Drinking water filtration • Cooking & Food preparation • Instant Hot or Chilled beverages • Sterilisation of baby bottles • Cocktails & Mocktails

* Based on a set volume of water being drawn every 30 seconds at an inlet temperature of average 21°C. Each cup equivalent to 170ml. Usage patterns and draw-off methods can impact recovery.

Accessories

990726 - Tubing Extension Kit for Sparkling unit - 2mtrs

Finishes

Standard Finishes

CH - Chrome	BR - Brushed
MB - Matte Black	MW - Matte White

Special Order Finishes

RG - Rose Gold	BRG - Brushed Rose Gold
GM - Gun Metal Grey	UB - Urban Brass

Add the relevant Finishes Code to the Product SKU to finalise your specification eg 915000GMB

TECHNICAL DRAWING & INSTALLATION REQUIREMENTS

PRODUCT DIMENSIONS

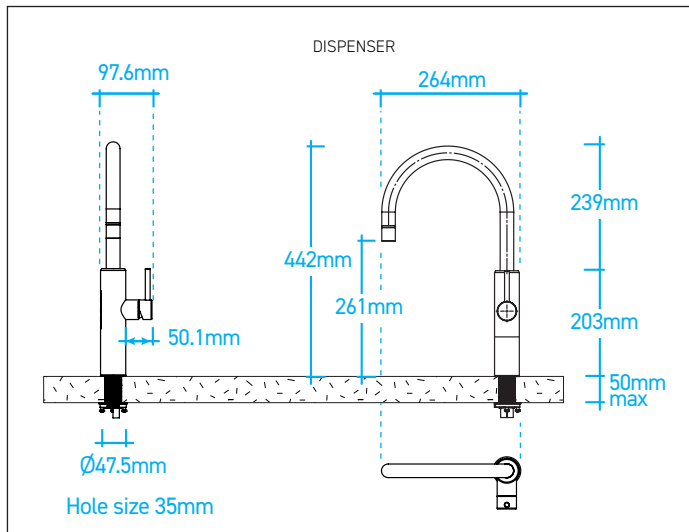

PREFERRED INSTALLATION LAYOUT

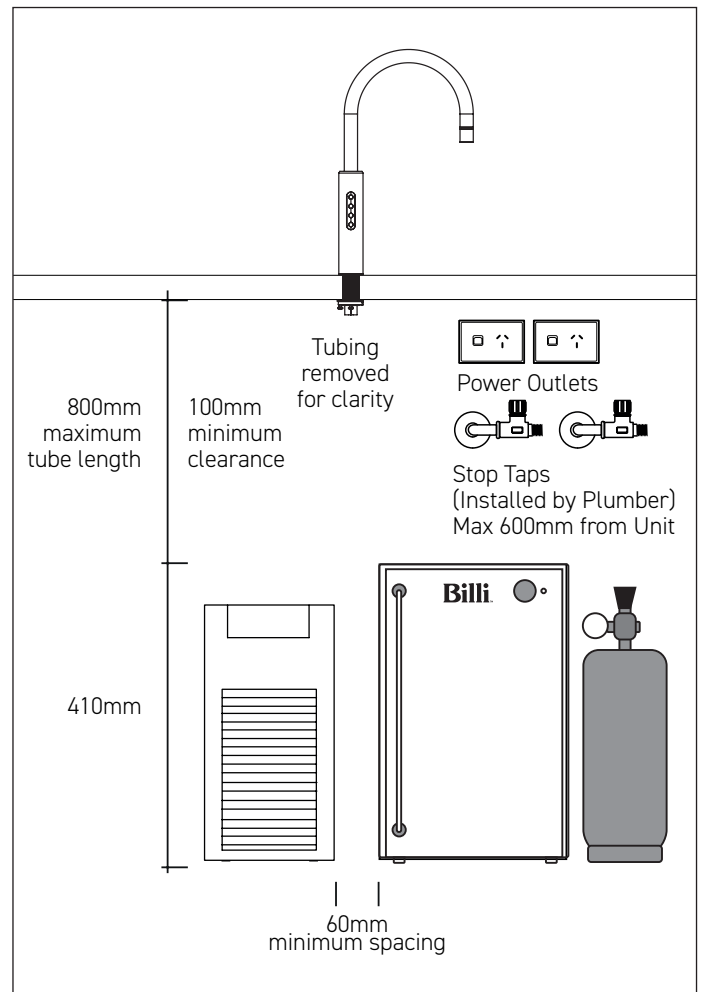

WATER SUPPLY

Domestic Cold and Hot mains supply is required via separate 1/2" BSP (15mm) stop-taps with male threads. These should be pre-installed in an easily accessible position. Water supply must be microbiologically safe to drink, with a minimum dynamic water pressure of 250kPa and a maximum of 1000kPa.

POWER SUPPLY

Two (2 of) standard 10 amp power outlets are required, no further than 1000mm from the underbench unit. The system is supplied with a 1 metre flex cord and plug.

FILTRATION

Billi's range of premium filters utilise BWT's unique Fibron X technology. Billi's filter range provides superior taste, water quality, consistent filter life and peace of mind when it comes to hygiene.

Filter supplied: 994052 (0.2 micron). Replacement filters available: 994051 (5 micron option), 994054 (HSD option), 994056 (Sediment only) and 994060 (0.2 micron Sediment Only).

CERTIFICATIONS

Every Billi drinking water appliance is manufactured under a certified quality control system. All Billi commercial range models have been tested and comply with all required standards including: Watermark: WM-022690; Tested to AT55200.105 and AS/NZ 4020; ISO 9001:2015, GEC 11627; AS1428; WELL Cornerstone Member; WELS 5 Star Rating: WM-021914.

CO₂ Cylinder

The CO₂ gas cylinder supplied must be secured in a suitable location. Each cylinder contains 1100g of CO₂ and should be installed in a well ventilated area. Each cylinder will provide between 200-350L of sparkling water depending on the unit settings. The MSDS is available on www.billi.com.au for a complete list of specifications and warnings. Replacement gas cylinders are available from Billi. CO₂ Cylinder - single 996911 or double 996912.

WARRANTY

The Billi Home Range is covered by a comprehensive 2 year warranty on all parts and labour.

Billi®



Billi Australia Pty Ltd

P 1800 812 321
W www.billi.com.au

Billi New Zealand Ltd

P 0800 636 0 636
W www.billi.co.nz

visit us at

