

COMMERCIAL DATA SHEET

Alpine 125 MMT



Billi Alpine 125 with Gooseneck Multifunction Mixer Tap

Enjoy refreshing chilled or a continuous supply of ambient temperature filtered water.
 Billi's Alpine 125 offers a premium filtered drinking water experience to account for all preferences.
 The Good Design Award Winning Multifunction Mixer tap complements the space saving and multifunctional approach of Billi's Alpine range perfectly, negating the requirement for an additional domestic supply mixer tap while providing a sleek solution to dispensing filtered water.



STILL CHILLED



Multifunction Mixer Tap

Alpine Under-Bench Unit



Features

SPACE SAVING DESIGN	ENERGY EFFICIENT	NO CUPBOARD VENTILATION REQUIRED	UNLIMITED FILTERED WATER	ADJUSTABLE CHILLED TEMPERATURE
WATER COOLED TECHNOLOGY	CHOICE OF DISPENSER DESIGNS	AUSTRALIAN DESIGNED & MADE	AWARD WINNING DESIGN	HACCP CERTIFIED

PRODUCT SPECIFICATIONS

Water type	Product code	Model name	Dispenser	Suggested no. of people	Chilled water delivery (cups per hour)	Still water delivery (cups per hour)	Power supply (amps)
 STILL CHILLED	932125G	Alpine 125	Multifunction Mixer Tap	Up to 40	120	unlimited	10

* Based on a set volume of water being drawn every 30 seconds at an inlet temperature of average 21°C. Each cup equivalent to 170ml. Usage patterns and draw-off methods can impact recovery.

Accessories

990720 - Tubing Extension Kit for X series dual temp dispensers 2mtrs

Finishes

Standard Finishes

CH - Chrome	BR - Brushed
MB - Matte Black	MW - Matte White

Special Order Finishes

RG - Rose Gold	BRG - Brushed Rose Gold
GM - Gun Metal Grey	UB - Urban Brass

Add the relevant Finishes Code to the Product SKU to finalise your specification eg 932125GMB

TECHNICAL DRAWING & INSTALLATION REQUIREMENTS

PRODUCT DIMENSIONS

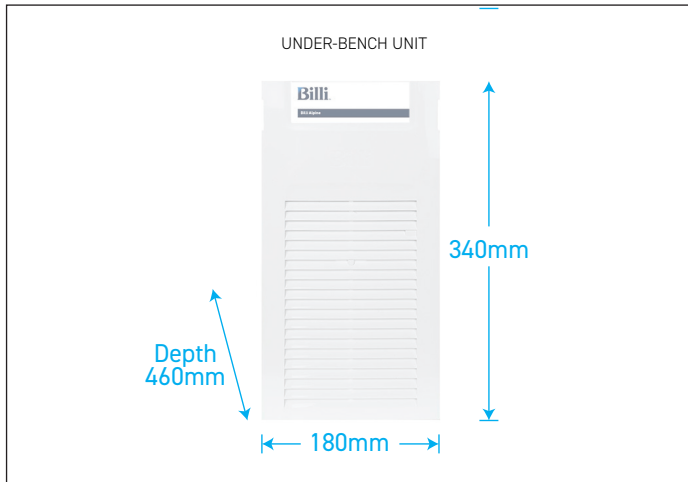
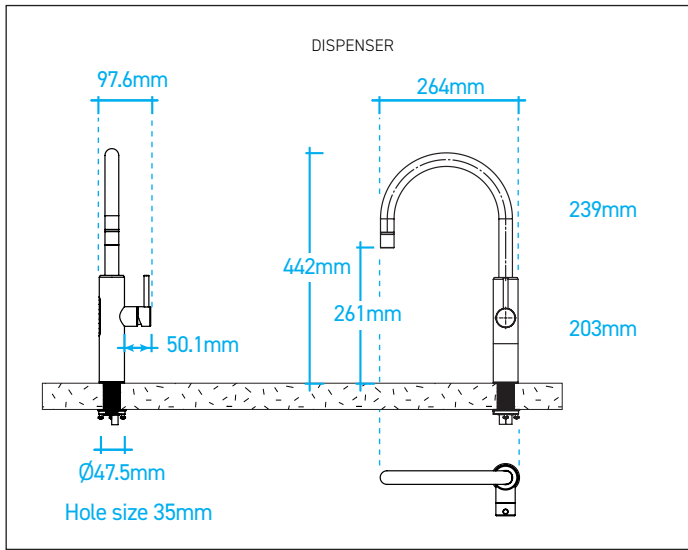

PREFERRED INSTALLATION LAYOUT

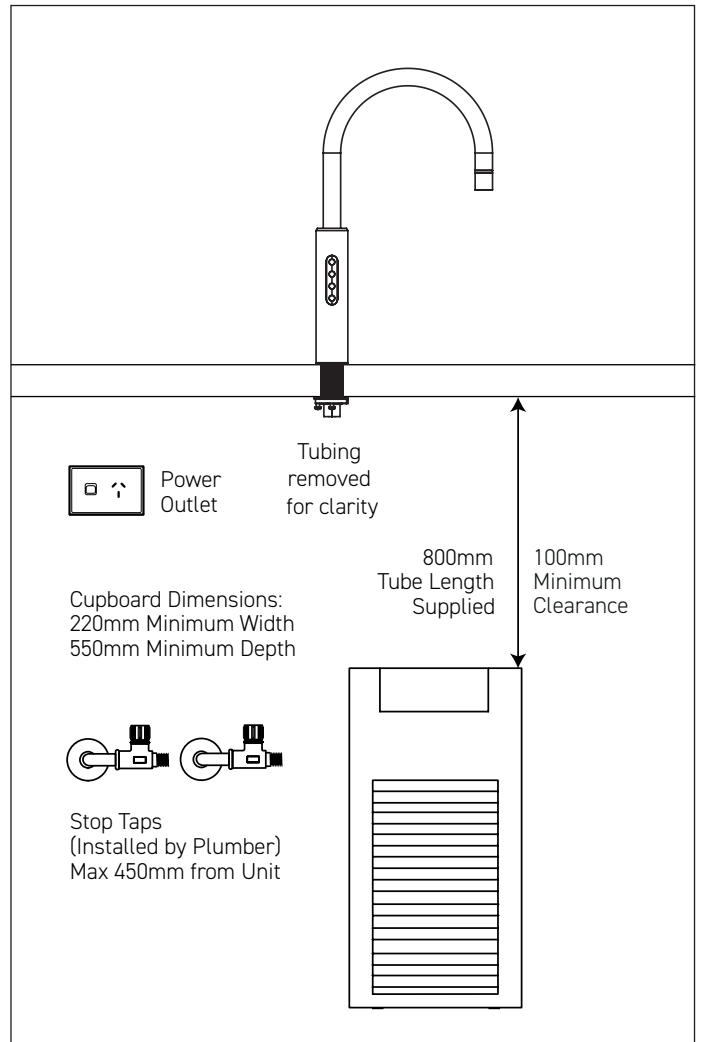

WATER SUPPLY

Domestic Cold and Hot mains supply is required via separate 1/2" BSP (15mm) stop-taps with male threads. These should be pre-installed in an easily accessible position. Water supply must be microbiologically safe to drink, with a minimum dynamic water pressure of 250kPa and a maximum of 1000kPa.

POWER SUPPLY

A standard 10 amp power outlet is required, no further than 1000mm from the underbench unit. The system is supplied with a 1 metre flex cord and plug.

WARRANTY

The Billi Alpine Range is covered by a comprehensive 2 year warranty on all parts and labour.

FILTRATION

Billi's range of premium filters utilise BWT's unique Fibron X technology. Billi's filter range provides superior taste, water quality, consistent filter life and peace of mind when it comes to hygiene.

Filter supplied: 994051 (5 micron). Replacement filters available: 994052 (0.2 micron), 994054 (HSD option), 994056 (Sediment only) and 994060 (0.2 micron Sediment Only).

CERTIFICATIONS

Every Billi drinking water appliance is manufactured under a certified quality control system. All Billi commercial range models have been tested and comply with all required standards including: Watermark: WM-021525; HACCP: PE-872-WAT-1-02; ISO 9001:2015, QEC 11627; Tested to ATS5200.105 and AS/NZ 4020; Section J6.6 of the BCA; WELL Cornerstone Member; WELS 5 Star Rating: WM-021914.

Billi®



Billi Australia Pty Ltd

P 1800 812 321

W www.billi.com.au

Billi New Zealand Ltd

P 0800 636 0 636

W www.billi.co.nz

visit us at

